



**Heavy Duty
Air Band Transceiver**

VXA-150

Service Manual

© 2001 VERTEX STANDARD CO., LTD. Printed in Japan.

VERTEX STANDARD CO., LTD.

4-8-8 Nakameguro, Meguro-Ku, Tokyo 153-8644, Japan

VERTEX STANDARD

US Headquarters

17210 Edwards Rd., Cerritos, CA 90703, U.S.A.

International Division

8350 N.W. 52nd Terrace, Suite 201, Miami, FL 33166, U.S.A.

YAESU EUROPE B.V.

P.O. Box 75525, 1118 ZN Schiphol, The Netherlands

YAESU UK LTD.

Unit 12, Sun Valley Business Park, Winnall Close

Winchester, Hampshire, SO23 0LB, U.K.

VERTEX STANDARD HK LTD.

Unit 5, 20/F., Seaview Centre, 139-141 Hoi Bun Road,

Kwun Tong, Kowloon, Hong Kong

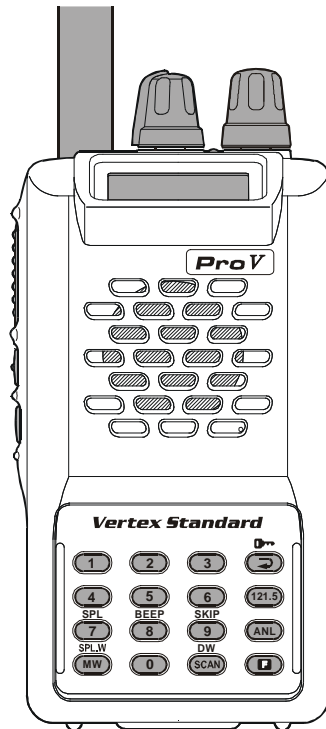

Pro V

The Vertex Standard **VXA-150 Pro V** is a compact, stylish, solid hand-held transceiver providing communication (transmit and receive) capability on the International Aircraft Communication Band (“**COM**” band: 118 ~ 136.975 MHz), and it additionally provides receive on the “**NAV**” band (108 ~ 117.975 MHz).

The **VXA-150** includes our exclusive two-mode display with upright or inverted viewing when on your belt, NOAA weather band monitoring, 8-character Alpha/Numeric Display, 50 Memory Channels, and 100 “Book Memory” Channels.

The following pages describe the Controls & Connectors, Accessories & Options, and Specification of the **VXA-150**. With proper care and operation, the transceiver will provide many years of reliable communications.

Contents

Operating Manual Reprint	2	Circuit Description	11
Specifications	6	Alignment	14
CE32 Programming Software	7	Board Unit (Schematics, Layouts & Parts)	17
Exploded View & Miscellaneous Parts....	9	MAIN Unit	17
Block Diagram	10	VR Unit	30
		SW Unit	31

CONTROLS & CONNECTORS

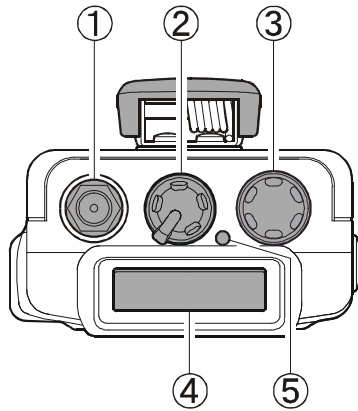

TOP Panel

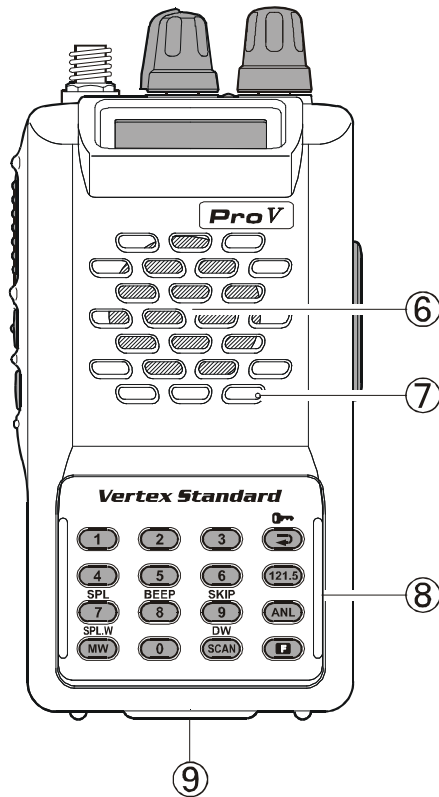

Front Panel

- ① **Antenna Jack**
This SMA jack accepts the supplied flexible antenna, or another antenna designed to provide 50 Ω impedance on the Aircraft Communication Band.
- ② **POWER/VOLUME Knob**
Turn this control clockwise to turn the radio on and to increase the volume. Counterclockwise rotation into the click-stop will turn the radio off.
- ③ **CHANNEL Selector Knob**
This 20-position detented rotary switch tunes the operating frequency or selects the memory channels. Pressing this knob downward momentarily selects the tuning methods among the **VFO** (Variable Frequency Oscillator), **MR** (Memory Recall), **BOOK** (Pre-Programmed Memories), and **WX** (Weather Channel Memories) mode.
- ④ **LCD (Liquid Crystal Display)**
The display shows the selected operating conditions as indicated on the next page.
The display may be changed to “inverted” viewing via the Menu.
- ⑤ **BUSY/TX Indicator Lamp**
This lamp glows **green** when a signal is being received and **red** when transmitting.
- ⑥ **Loudspeaker**
The internal speaker is located in this position.
- ⑦ **Microphone**
Speak across this opening in a normal voice level while pressing the **PTT** switch.
- ⑧ **Keypad**
Several keys have dual functions.
The **primary** functions are labeled on the key top (activated by simply pressing the key momentarily), while **secondary** functions are labeled in yellow above the top edge of the key (activated by pressing the [F] key first, then the indicated key).

CONTROLS & CONNECTORS

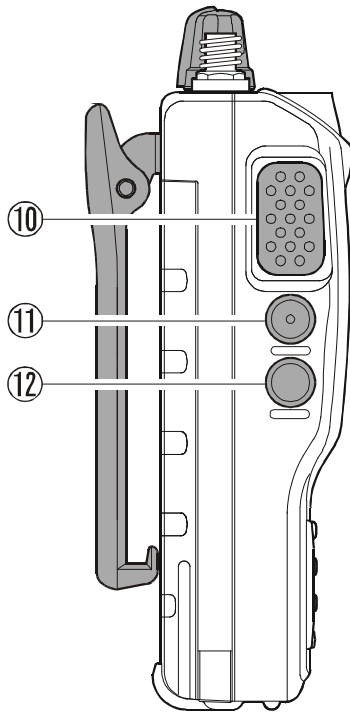

Left Side

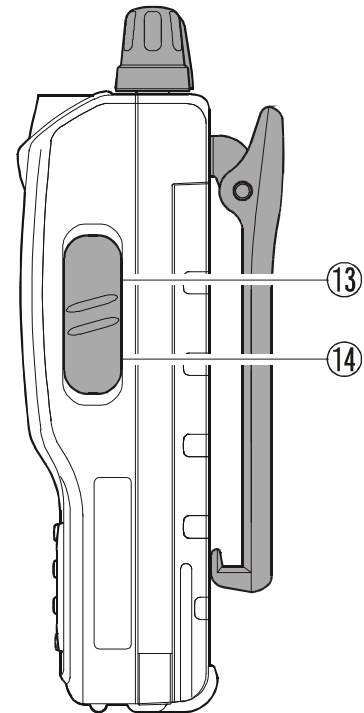

Right Side

- ⑨ **Battery Pack Latch**
Open this latch for battery removal.
- ⑩ **PTT (PUSH TO TALK) Switch**
Press this button to transmit when you are operating in the **COM** band. Release this button to return to the “RECEIVE” mode.
- ⑪ **MONITOR Switch**
This button may be pressed to “open” the squelch manually, allowing you to listen for very weak signals. Press and hold this button for 2 seconds to “open” the squelch continuously. Press this button again to resume normal (quiet) monitoring.
- ⑫ **LAMP Switch**
Pressing the **LAMP** switch momentarily will illuminate the display and keypad for five seconds, after which the back-lighting will automatically turn off. Press and hold this switch for 2 seconds to activate the back-lighting lamp continuously. To turn the lamp off, press this switch again. The **LAMP** switch may be configured in several ways via the Menu.

- ⑬ **MIC/EAR Jack**
You may connect the supplied **CT-60** Headset Cable or the (optional) **MH-44A4B** Speaker/Microphone to this jack.
 **Never connect any Speaker/Microphone that is not recommended by the manufacturer. Because these jack connections are unique, using a Speaker/Microphone that is not specified by Vertex Standard may damage the VXA-150.**
- ⑭ **EXT DC Jack**
When an external 12-Volt DC power source is available, you may connect the (optional) **E-DC-5B** External DC Cable here. **Do not connect any wire to this jack if that wire is connected directly to a 28-Volt DC source.** Connecting the **VXA-150** directly to a source which exceeds 15.0 Volts DC will result in damage to the unit.

Operating Manual Reprint (Partial)

KEYPAD

Primary Function (Press Key)	Frequency Entry Digit 1	Frequency Entry Digit 2	Frequency Entry Digit 3	Selects Memory Display Type
Secondary Function (Press +)	None	None	None	Locks the Keypad
Primary Function (Press Key)	Frequency Entry Digit 4	Frequency Entry Digit 5	Frequency Entry Digit 6	Selects Emergency Channel (121.5 MHz)
Secondary Function (Press +)	None	None	None	None
Primary Function (Press Key)	Frequency Entry Digit 7	Frequency Entry Digit 8	Frequency Entry Digit 9	Activates Automatic Noise Limiter
Secondary Function (Press +)	Activates Split (Duplex) mode	On/Off Switch for Keypad Beeper	Allows Skipping of Channel during Scan	None
Primary Function (Press Key)	Memory "Write" Command	Frequency Entry Digit 0	Activates Scanning	Activates "Secondary" Key mode
Secondary Function (Press +)	Split-Memory "Write" Command	None	Activates Dual Watch	None

LCD DISPLAY

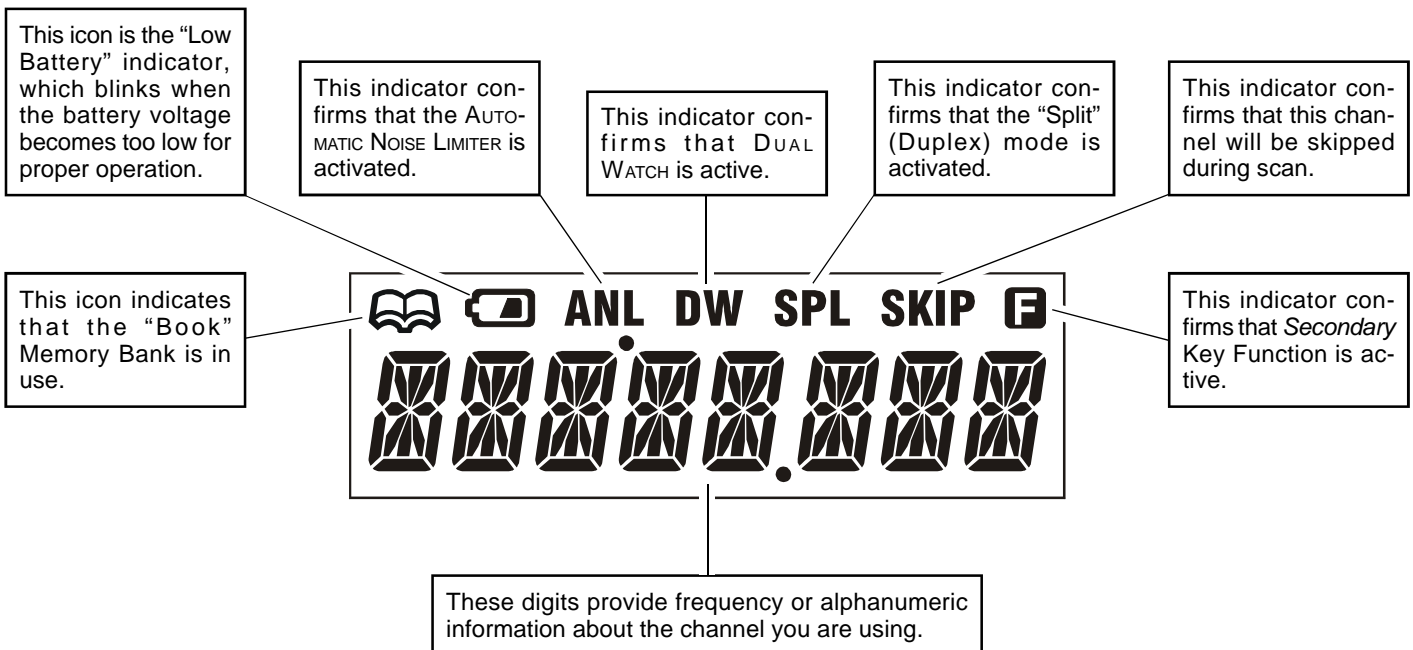

FIELD PROGRAMMING MODE

The **VXA-150**'s Book Memories also allow the user to store, label, and recall channel frequencies which you may want to use frequently while the **VXA-150** is in the Field Programming mode.

Memory Storage into the Book Memory

- Press and hold the **PTT** and **LAMP** switches while turning the radio on, to activate the Field Programming Mode.
- Select the desired frequency to be stored in the Book Memory.
- Press and hold the **[MW(SPL.W)]** key for 2 seconds. The display will indicate "BOOK:" and a channel number will blink on the LCD.
- Within five seconds of pressing the **[MW(SPL.W)]** key, rotate the **CHANNEL** selector knob to select the desired memory channel number for storage.
- Now press and hold in the **[MW(SPL.W)]** key for 2 seconds; you will now see "....." on the LCD. To attach an alpha/numeric name (label) to the memory, proceed to the next step; otherwise press and hold the **[MW(SPL.W)]** key for 2 seconds to save the entry and exit.
- To label a memory with an alpha/numeric name, the next step is to use the **CHANNEL** selector knob to select any of the 48 available characters (including letters, numbers, and special symbols). When the desired first character appears, press down on the **CHANNEL** selector knob momentarily to move on to the next character.
- Select succeeding characters in the same manner, pressing down on the **CHANNEL** selector knob momentarily after each selection.
- After entering the entire name (eight characters maximum), press the **[MW(SPL.W)]** key for 2 seconds to save all data for the channel.
- Turn the radio off, then turn the radio back on again to begin normal operation.

ACCESSORIES & OPTIONS

Supplied Accessories

Ni-Cd Battery Pack	FNB-64
Overnight Charger	NC-72B/C/U [※]
Helical Antenna	ATV-7
Headset Cable	CT-60
Operating Manual	
Warranty Card	

※: "**B**" suffix is for use with 120 VAC,
"**C**" suffix is for use with 230-240 VAC, or
"**U**" suffix is for use with 230 VAC.

Available Options

MH-44A4B	Speaker Microphone
FNB-V57	Ni-Cd Battery Pack (7.2V, 1100mAh) (Requires VAC-400 or NC-76)
FBA-25	Alkaline Battery Case
VAC-400	Desktop Rapid Charger
NC-76B/C/U [※]	Overnight Desktop Charger
E-DC-5B	External Power Cable
CN-3	Antenna Adapter

Availability of accessories may vary. Some accessories are supplied as standard per local requirements, while others may be unavailable in some regions. Consult your Vertex Standard Dealer for details regarding these and any newly-available options.

Connection of any non-Vertex Standard-approved accessory, should it cause damage, may void the Limited Warranty on this apparatus.

Specifications

General

Frequency Range:	TX: 118.000 - 136.975 MHz, RX: 108.000 - 136.975 MHz, Weather Channels (WX-01 - WX-10)
Channel Spacing:	25 kHz
Emission Type:	TX: AM, RX: AM & FM
Supply Voltage:	6.0 - 15.0 VDC
Current Consumption (approx.):	< 1 μ A (power off), 17 mA (battery saver on, saver ratio 1:5), 47 mA (squelch on), 180 mA (receive), 1 A (transmit 1.5 W Carrier)
Temperature Range:	+14 °F to + 140 °F (-10 °C to +60 °C)
Case Size (WxHxD):	2.3 x 4.3 x 1.0 inches (58 x 108.5 x 26.5 mm) w/FNB-64
Weight (approx.):	0.75 lb (340 grams) with FNB-64, antenna, and belt clip

Receiver

Circuit Type:	Double-conversion superheterodyne
IFs:	35.4 MHz & 450 kHz
Sensitivity:	<0.8 μ V (for 6 dB S/N with 1 kHz, 30 % modulation)
Selectivity:	>8 kHz/-6 dB
Adjacent CH. Selectivity:	<25 kHz/-60 dB
AF Output (@7.2 V):	0.4 W @ 8 Ohms, 10 % THD

Transmitter

Power Output (@ 7.2 V):	5.0 W (PEP), 1.5 W (Carrier Power)
Frequency Stability:	Better than \pm 10 ppm (+14 °F to + 140 °F [-10 °C to +60 °C])
Modulation System:	Low Level Amplitude Modulation
Spurious Emission:	>60 dB below carrier
Int. Microphone Type:	Condenser
Ext. Mic. Impedance:	150 Ohms

Specifications are subject to change without notice or obligation.

CE32 Programming Software

CE32 Programming Software Instructions

With the CE32 programming Software you can quickly and easily program the features and memories of the Vertex Standard **VXA-150** heavy duty air band transceiver from your personal computer. The CE32 Programming Software allows custom memory files to be stored, saved, merged, and edited for convenience when planning a journey. In the event of an accidental memory failure, transceiver memory and configuration data may be re-loaded in a matter of minutes.

The CE32 Programming Software diskette contains the following files:

- CE32.EXE - The executable programming software;
- CE32.HLP - The "Help" file used with the main program; and
- CE32.CFG - The "Configuration" file for the main program.

Before connecting the **VXA-150** for programming, turn off both the computer and the **VXA-150**. Now connect the CT-42A PC Programming Cable to the computer's serial port and the **VXA-150** as shown in the illustration. Then it will be safe to restart the computer; turning off the equipment during interconnection avoids damage to the electronics caused by voltage spikes.

Insert the distribution diskette into your 3½" drive (after booting DOS), and make a copy of the diskette; use the distribution diskette for archive purposes, and use the disk copy for programming.

Place the CE32 (copy) diskette into your 3½" drive (usually "Drive A"), and log onto this drive by typing **A:[ENTER]**. At this point, you may make a directory for the CE32 software, if you like, according to standard DOS procedures (using the **MKDIR** command). Load the contents of the CE32 diskette into this directory, using the **COPY** command (e.g. **COPY A:*. * C:\ [directory name]**).

Now type **CE32 [ENTER]** to start the program. The introductory screen will appear, and you may press any key to enter the main screen, as shown below.

Choose the "Help" contents option from the program's Menu for assistance with program operation.

Important Note!

Do not work directly with the CE32 programming diskette. Make a copy of it and use the copy when programming the **VXA-150**. Keep it and the original distribution diskette in a safe place in case you need to make another copy of it later.

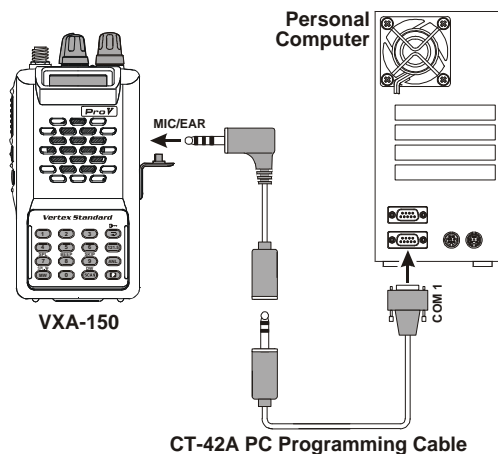

CE32 Programming Setup

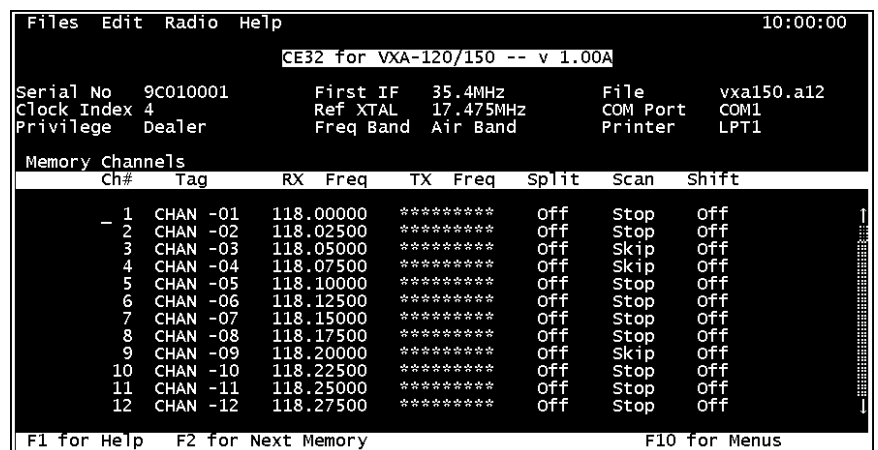

CE32 Main Screen

Notes

Exploded View & Miscellaneous Parts

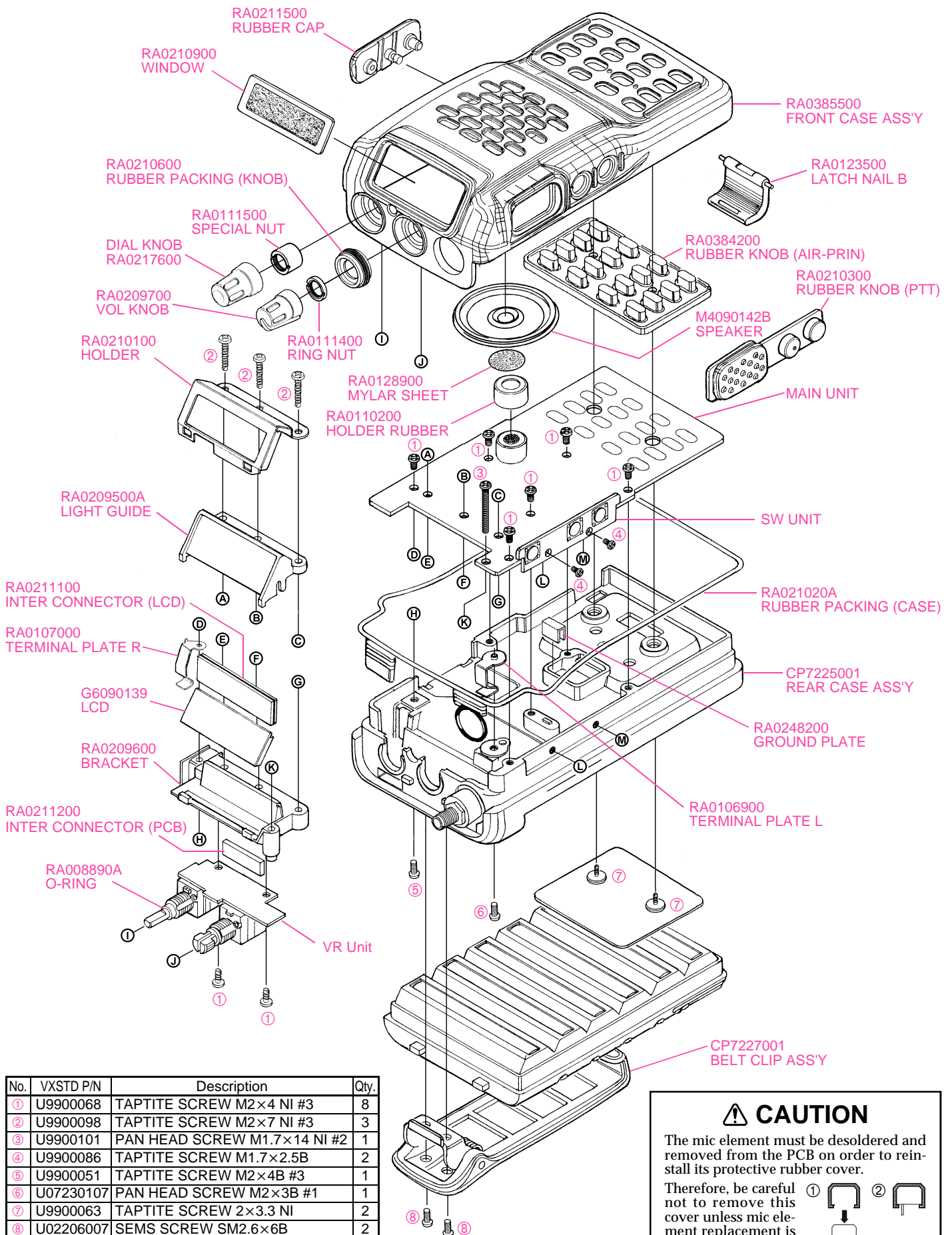

No.	VXSTD P/N	Description	Qty.
①	U9900068	TAPTITE SCREW M2×4 NI #3	8
②	U9900098	TAPTITE SCREW M2×7 NI #3	3
③	U9900101	PAN HEAD SCREW M1.7×14 NI #2	1
④	U9900086	TAPTITE SCREW M1.7×2.5B	2
⑤	U9900051	TAPTITE SCREW M2×4B #3	1
⑥	U07230107	PAN HEAD SCREW M2×3B #1	1
⑦	U9900063	TAPTITE SCREW 2×3.3 NI	2
⑧	U02206007	SEMS SCREW SM2.6×6B	2

Non-designated parts are available only as part of a designated assembly.

⚠ CAUTION

The mic element must be desoldered and removed from the PCB in order to re-install its protective rubber cover. Therefore, be careful not to remove this cover unless mic element replacement is necessary.

Block Diagram

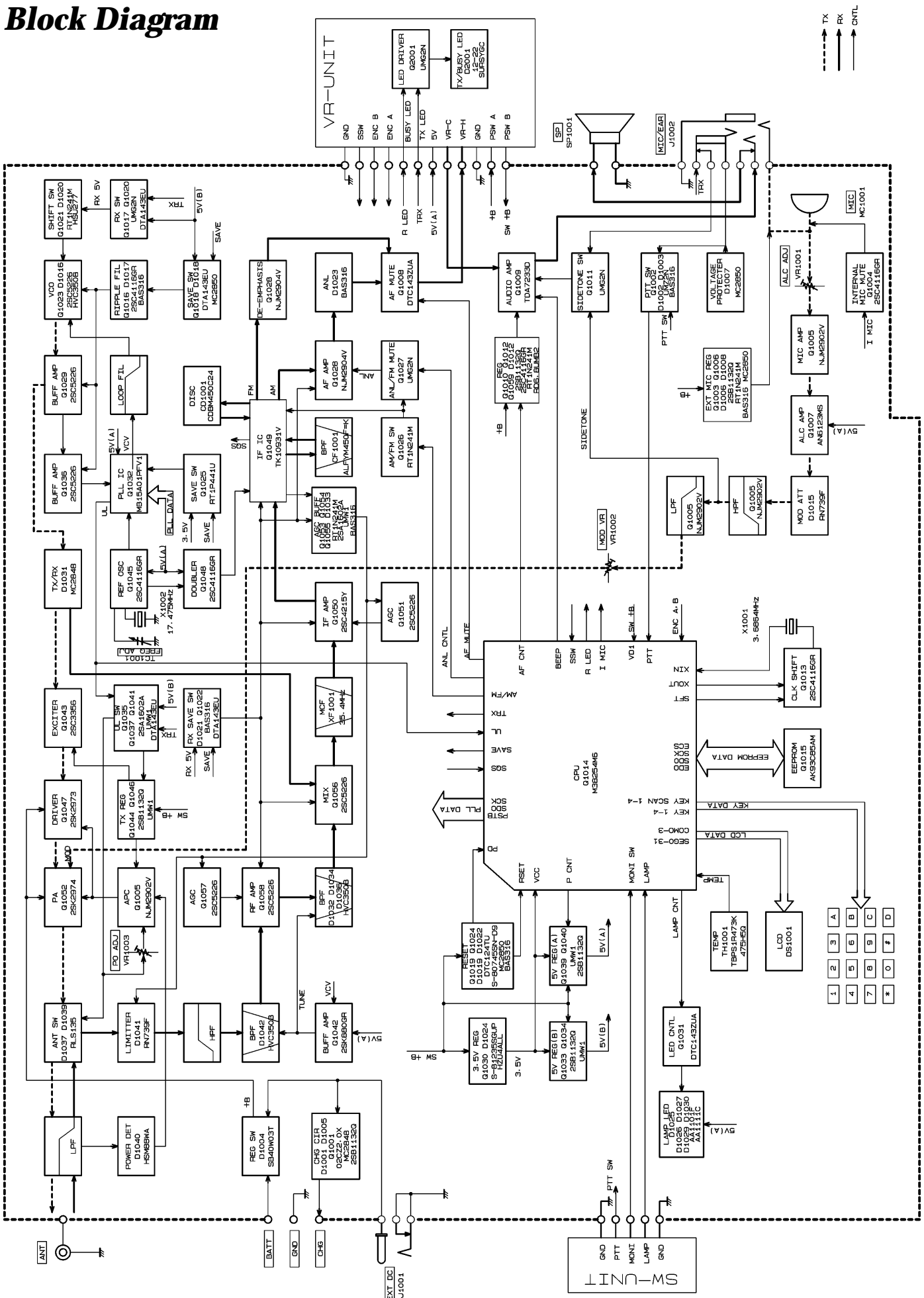

TX
RX
CNTL

Circuit Description

Receive Signal Path

Incoming RF from the antenna jack is passed through a low-pass filter and high-pass filter consisting of coils L1022, L1024, L1026, L1027, L1030, & L1031, capacitors C1237, C1239, C1242, C1245, C1247, C1248, C1249, C1250, C1251, C1252, C1255, & C1257 and antenna switching diodes **D1037** and **D1039** (both **RLS135**) to the receiver front end section.

Signals within the frequency range of the transceiver are applied to the receiver front end which contains RF amplifier **Q1058 (2SC5226)** and varactor-tuned band-pass filter consisting of coils L1013, L1017, L1020, L1021, L1028, & L1029, capacitors C1198, C1204, C1205, C1212, C1216, C1217, C1222, C1228, C1232, C1243, & C1253, and diodes **D1032, D1034, D1036 & D1042** (all **HVC350**), then applied to the 1st mixer **Q1056 (2SC5226)**.

Buffered output from the VCO is amplified by **Q1029 (2SC5226)** to provide a pure 1st local signal between 143.4 and 172.4 MHz for injection to the 1st mixer. The 35.4 MHz 1st mixer product then passes through monolithic crystal filter **XF1001 (35S15A, 7.5 kHz BW)** which strips away all but the desired signal, which is then amplified by mixer postamp **Q1050 (2SC4215Y)**.

The amplified 1st IF signal is applied to the AM/FM IF subsystem IC **Q1049 (TK10931V)**, which contains the 2nd mixer, limiter amplifier, and AM/FM detector.

A 2nd local signal is generated by PLL reference/2nd local oscillator **Q1045 (2SC4116GR)** from the 17.475 MHz crystal **X1002**. The 17.47 MHz signal is doubled by **Q1048 (2SC4116GR)** to produce the 450 kHz 2nd IF when mixed with the 1st IF signal within **Q1049**. The 2nd IF then passes through the ceramic filter **CF1001 (ALFYM450F=K)** to strip away unwanted mixer products.

In the FM mode, a 2nd IF signal from the ceramic filter **CF1001** applied to the limiter amplifier section of **Q1049**, which removes amplitude variations in the 450 kHz IF before detection of the speech by the ceramic discriminator **CD1001 (CDBM450C24T)**. Detected audio from **Q1049** is passed through the de-emphasis, consisting of the resistors R1089, R1095, R1100, & R1149, capacitors C1104, C1105, C1107, & C1151, and **Q1028-2 (NJM2904V)**.

In the AM mode, detected audio from **Q1049** is passed through the audio amplifier **Q1028-1 (NJM2904V)** and ANL circuit, then applied to the AF amplifier **Q1028-2 (NJM2904V)**. When ANL is on, the ANL MUTE gate **Q1027 (UMG2)** goes high, the low-pass filter/limiter con-

sisting of capacitor C1124, resistors R1105, R1111, R1112, R1115, & R1119 and diode **D1023 (BAS316)** is activate, thus reducing the pulse noises when impulse noise received.

The processed audio signal from **Q1028-2** passes through the audio mute gate **Q1008 (DTC143ZUA)** and the volume control to the audio power amplifier **Q1009 (TDA7233D)**, providing up to 0.4 Watts to the headphone jack or 8 Ω loudspeaker.

A portion of the AF signal from the AM/FM IF subsystem **Q1049** converted into DC voltage within the IC, and then passes through the AGC amplifier **Q1054 (2SA1602A)** and **Q1055 (UMW1)** to the inversion amplifiers **Q1051** and **Q1057** (both **2SC5226**). These amplifiers reduce the gain of the IF amplifier **Q1050** and the RF amplifier **Q1058** while receiving a strong signal.

Squelch Control

When a signal is received, a DC squelch control voltage appears at pin 15 of AM/FM IF subsystem **Q1049** according to the receiving signal strength. This DC is applied to pin 2 of microprocessor **Q1014**.

The DC squelch control voltage is compared with the SQL threshold level by the microprocessor **Q1014**. If the DC squelch control voltage is higher, pin 49 of **Q1014** goes low. This signal disable the AF MUTE gate **Q1008 (DTC143ZUA)**, thus activating the AF audio.

Also, the microprocessor stops scanning, if active, and allows audio to pass through the AF MUTE gate **Q1008**.

Transmit Signal Path

Speech input from the microphone is passed through the microphone sensitivity potentiometer VR1001 and microphone amplifier **Q1005-3 (NJM2902V)**, then applied to the ALC amplifier **Q1007 (AN6123MS)**. The amplified speech signal is passed through the high-pass filter **Q1005-1 (NJM2902V)** and low-pass filter **Q1005-2 (NJM2902V)** which AM modulate the Tx frequency with speech signal.

When using the optional headset, the SIDETONE signal from **Q1011 (UMG2)** becomes "HIGH", turning **Q1012 (2SC4116GR)** on, therefore a portion of the speech signal applied to the AF power amplifier **Q1009** as a monitor signal.

The carrier signal from the VCO **Q1023 (2SC5226)** passes through the buffer amplifier **Q1029 (2SC5226)** and

Circuit Description

TX/RX switch **D1031** (**MC2848**), then amplified by **Q1043** (**2SC3356**) and **Q1047** (**2SK2973**), then applied to the power amplifier **Q1052** which increases the signal level up to 5 watts output power.

The transmit signal then passes through the antenna switch **D1037** (**RLS135**), and is low-pass filtered to suppress away harmonic spurious radiation before delivery to the antenna.

Automatic Transmit Power Control

RF power output from the final amplifier is sampled by C1241/C1244 and is rectified by **D1040** (**HSM88WA**). The resulting DC voltage passes through the Automatic Power Controller **Q1005** (**NJM2902V**) to the APC attenuator **D1015** (**RN739F**), and final amplifier **Q1052** (**2SK2974**), so as to control the power output.

Transmit Inhibit

When the transmit PLL is unlocked, pin 7 of PLL chip **Q1032** (**MB15A01PFV1**) goes to a logic low. The resulting DC “unlock” control voltage is switches off TX inhibit switches **Q1035** (**2SA1602A**), **Q1037** (**UMW1**), and **Q1041** (**DTA143EU**) to disable the supply voltage to transmitter RF amplifier **Q1043**, disabling the transmitter.

Spurious Suppression

Generation of spurious products by the transmitter is minimized by the fundamental carrier frequency being equal to the final transmitting frequency. Additional harmonic suppression is provided by a low-pass filter consisting of L1024, L1026, & L1030 and C1242, C1245, C1247, C1249, C1252, & C1257, resulting in more than 60 dB of harmonic suppression prior to delivery of the RF signal to the antenna.

PLL Frequency Synthesizer

PLL circuitry consists of VCO **Q1023** (**2SC5226**), VCO buffer **Q1029** & **Q1036** (both **2SC5226**), and PLL subsystem IC **Q1032** (**MB15A01PFV1**), which contains a reference divider, serial-to-parallel data latch, programmable divider, phase comparator and charge pump.

Stability is maintained by a regulated 3.5 V supply via **Q1030** (**S-81235SGUP-DQI**) which feeds the PLL reference oscillator **Q1045** (**2SC4116GR**), as well as capacitors associated with the 17.475 MHz frequency reference crystal X1002.

In the receive mode, VCO **Q1023** oscillates between 143.4 and 172.4 MHz. The VCO output is buffered by **Q1029** and **Q1036**, and applied to the prescaler section of **Q1032**. There the VCO signal is divided by 64 or 65, according to a control signal from the data latch section of **Q1032**, before being applied to the programmable divider section of **Q1032**. The data latch section of **Q1032** also receives serial dividing data from the microprocessor **Q1014** (**M38254M6**), which causes the pre-divided VCO signal to be further divided in the programmable divider section, depending upon the desired receive frequency, so as to produce a 5 kHz derivative of the current VCO frequency.

Meanwhile, the reference divider section of **Q1032** divides the 17.475 MHz crystal reference from the reference oscillator **Q1045** by 3495 to produce the 5 kHz loop reference. The 5 kHz signal from the programmable divider (derived from the VCO) and that derived from the reference oscillator are applied to the phase detector section of **Q1032**, which produces a pulsed output with pulse duration depending on the phase difference between the input signals. This pulse train is filtered to DC and returned to the varactor **D1015** (**HVC350B**).

Changes in the level of the DC voltage applied to the varactors affect the reactance in the tank circuit of the VCO, changing the oscillating frequency of the VCO according to the phase difference between the signals derived from the VCO and the crystal reference oscillator. The VCO is thus phase-locked to the crystal reference oscillator.

The output of the VCO **Q1023** is buffered by **Q1029** before application to the 1st mixer, as described previously.

For transmission, the VCO **Q1023** oscillates between 118 and 137 MHz. The remainder of the PLL circuitry is shared with the receiver. However, the dividing data from the microprocessor is such that the VCO frequency is at the actual transmit frequency (rather than offset for IFs, as in the receiving case).

Receive and transmit buses select which VCO is made active by **Q1021** (**RT1N241M**). FET **Q1042** (**2SK880GR**) buffers the VCV line for application to the tracking band-pass filters in the receiver front end.

When the power saving feature is active, the microprocessor periodically signals to the PLL IC **Q1032** to conserve power, and to shorten lock-up time.

Push-To-Talk Transmit Activation

The PTT switch on the microphone is fed through the PTT controller, **Q1002 (UMZ2N)**, to pin 41 of microprocessor **Q1014**, so that when the PTT switch is closed, pin 18 of **Q1014** goes high. This signals the microprocessor to activate the TX/RX controller **Q1017 (UMG2N)**, which cut off the receiver by disabling the 5 V supply bus at **Q1020 (DTA143EU)** which feeds the front-end, FM IF subsystem IC **Q1049**, and receiver VCO circuitry. At the same time, **Q1037 (UMW1)** and **Q1041 (DTA143EU)** activates the transmit 5 V supply line to enable the transmitter.

Alignment

The VXA-150 is carefully aligned at the factory for the specified performance across the Aircraft and Weather bands. Realignment should therefore not be necessary except in the event of a component failure.

The following procedures cover the adjustments that are not normally required once the transceiver has left the factory. However, if damage occurs and some parts subsequently are replaced, realignment may be required. If a sudden problem occurs during normal operation, it is likely due to component failure; realignment should not be done until after the faulty component has been replaced.

We recommend that servicing be performed only by authorized Vertex Standard service technicians who are experienced with the circuitry and fully equipped for repair and alignment. If a fault is suspected, contact the dealer from whom the transceiver was purchased for instructions regarding repair. Under no circumstances should any alignment be attempted unless the normal function and operation of the transceiver are clearly understood, the cause of the malfunction has been clearly pinpointed and any faulty components replaced, and realignment determined to be absolutely necessary. Problems caused by unauthorized attempts at realignment are not covered by the warranty policy.

Vertex Standard reserves the right to change circuits and alignment procedures, in the interest of improved performance, without notifying owners.

The following test equipment (and familiarity with its use) is necessary for complete realignment. While most steps do not require all of the equipment listed, the interactions of some adjustments may require that more complex adjustments be performed afterwards. Do not attempt to perform only a single step unless it is clearly isolated electrically from all other steps. Have all test equipment ready before beginning, and follow all of the steps in a section in the order presented.

Correction of problems caused by misalignment resulting from use of improper test equipment is not covered under the warranty policy.

Note: Signal levels in dB referred to in this procedure are based on $0 \text{ dB}\mu = 0.5 \text{ }\mu\text{V}$ (closed circuit).

Required Test Equipment

- Radio Tester with calibrated output level at 200 MHz
- In-line Wattmeter with 5% accuracy at 200 MHz
- 50- Ω , 10-W RF Dummy Load
- Regulated DC Power Supply adjustable from 3 to 15 VDC, 2A
- Frequency Counter: ± 0.2 ppm accuracy at 200 MHz
- AF Signal Generator
- AC Voltmeter
- DC Voltmeter: high impedance
- VHF Sampling Coupler

Alignment Preparation & Precautions

A 50- Ω RF load and in-line wattmeter must be connected to the main antenna jack in all procedures that call for transmission, except where specified otherwise. Correct alignment is not possible with an antenna. After completing one step, read the next step to see if the same test equipment is required. If not, remove the test equipment (except dummy load and wattmeter, if connected) before proceeding.

Correct alignment requires that the ambient temperature be the same as that of the transceiver and test equipment, and that this temperature be held constant between 68 ~ 86 °F (20 ~ 30 °C). When the transceiver is brought into the shop from hot or cold air, it should be allowed some time to come to room temperature before alignment. Whenever possible, alignments should be made with oscillator shields and circuit boards firmly affixed in place. Also, the test equipment must be thoroughly warmed up before beginning.

Set up the test equipment as shown below for transceiver alignment, apply 7.2 VDC power to the transceiver. Refer to the drawings for Alignment Points.

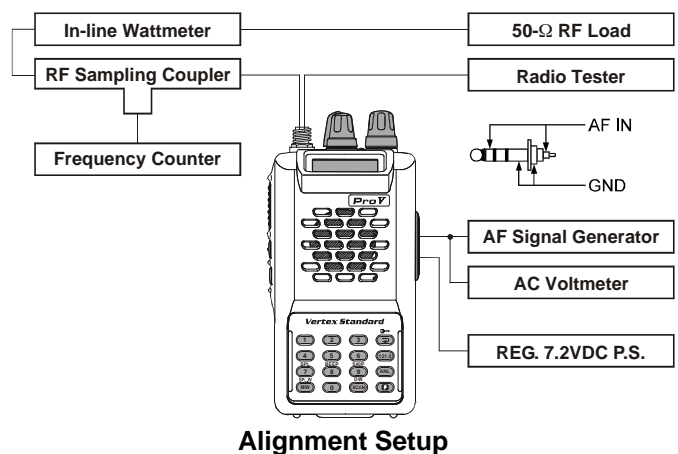

PLL Reference Frequency

- ❑ Connect the wattmeter, dummy load and frequency counter connected to the antenna jack, and tune the transceiver to 120.000 MHz.
- ❑ Transmit, and adjust **TC1001** on the MAIN Unit, if necessary, so the counter frequency is 120.000 MHz (± 100 Hz).

TX Power Adjustment

- ❑ Connect the wattmeter and dummy load to the antenna jack, and tune the transceiver to 128.000 MHz.
- ❑ Transmit, and adjust **VR1003** to obtain 1.5 W RF (carrier) power indicated on the wattmeter (without audio modulation input).

Tx Modulation Adjustment

- ❑ Connect the Radio Tester to the antenna jack, then adjust the AF generator output level for injection of 200 mV rms @ 1 kHz to the MIC jack. Leave the transceiver tuned to 127.500 MHz.
- ❑ Transmit, and adjust **VR1002** to obtain 85 % modulation (± 3 %) as indicated on the Radio Tester.
- ❑ Reduce the AF generator output level to 20 mV rms, then adjust **VR1001** to obtain 30 % modulation (± 3 %) on the Radio Tester.

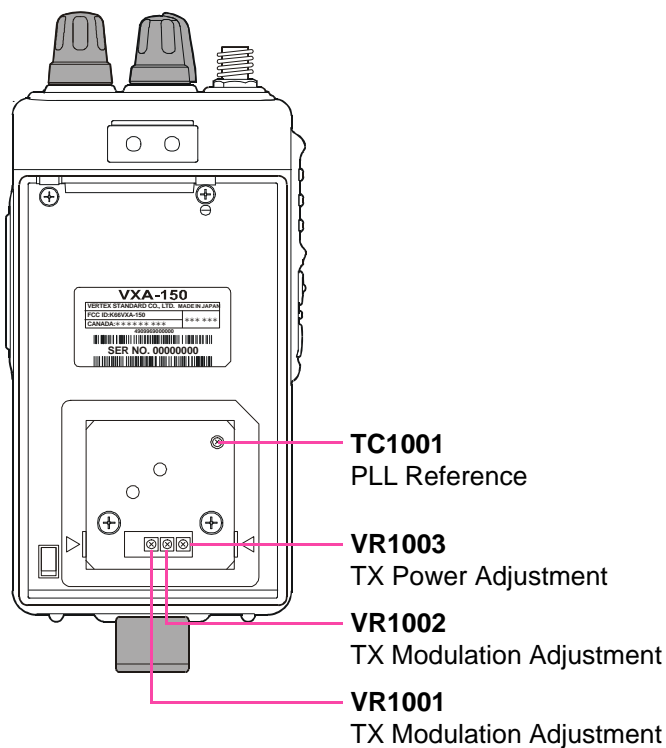

Alignment Point

Internal System Alignment Routine

This feature uses a programmed routine in the transceiver which replaces many previously-complex discrete component settings and adjustments with digitally-controlled settings via the **CHANNEL** selector knob. Transceiver adjustments include:

- *Squelch Hysteresis Adjustment*
- *Squelch Threshold Adjustment*
- *Squelch "Tight" Adjustment*

To begin, set the transceiver to 127.500 MHz, and turn the transceiver off. Then, press and holding the **LAMP** switch, **PTT** switch and the **CHANNEL** selector knob while turning the transceiver on.

Squelch Hysteresis Adjustment (HSSQ)

- ❑ Press the **CHANNEL** selector knob, then select the squelch hysteresis level using the **CHANNEL** selector knob.
- ❑ Next, press the **CHANNEL** selector knob.
- ❑ Rotate the **CHANNEL** selector knob to select the next setting.

Squelch Threshold Adjustment (THSQ)

- ❑ Inject a -9 dB μ (0.35 μ V) RF signal (with a standard modulation: 30 % AM modulation @ 1 kHz), then press the **CHANNEL** selector knob *twice*.
- ❑ Now rotate the **CHANNEL** selector knob to select the next setting.

Squelch "Tight" Adjustment (TISQ)

- ❑ Increase the RF signal level to +15 dB μ (5.6 μ V), then press the **CHANNEL** selector knob *twice*.
- ❑ Press and hold the in the **CHANNEL** selector knob for 2 second to save all setting and exit.

Resetting the CPU

If you are unable to gain control of the transceiver (or if you want to clear all memories and settings to their factory defaults), *press and holding* the **MONITOR** button and **PTT** switch while turning the transceiver on.

Note

MAIN Unit Circuit Diagram

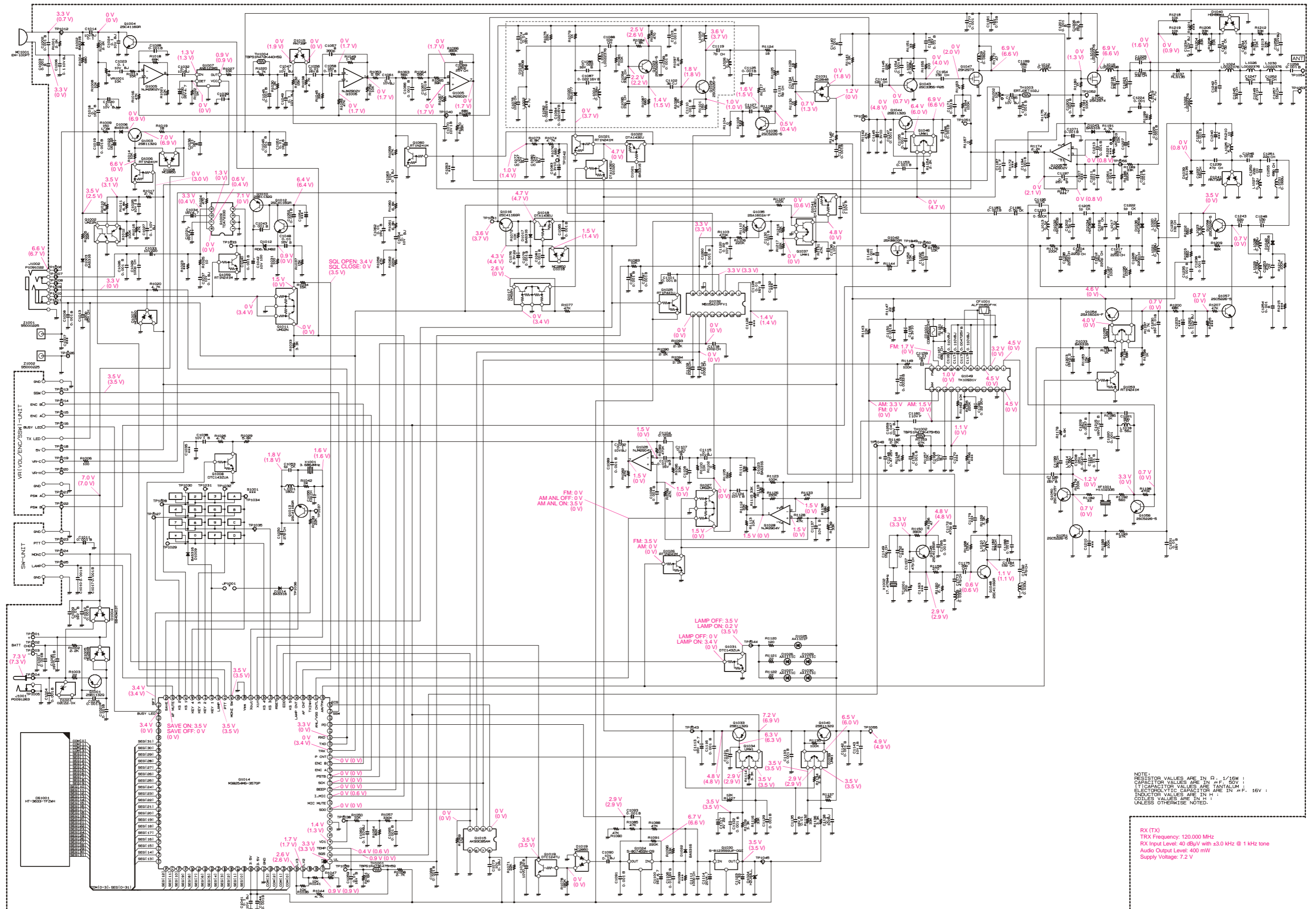

NOTE:
RESISTOR VALUES ARE IN Ω , 1/10W ;
CAPACITOR VALUES ARE IN μF , 50V ;
T \dagger CAPACITOR VALUES ARE TANTALUM ;
ELECTROLYTIC CAPACITOR ARE IN μF , 16V ;
COILS VALUES ARE IN H ;
UNLESS OTHERWISE NOTED.

RX (TX)
RX Frequency: 120.000 MHz
RX Input Level: 40 dB μ V with ± 3.0 kHz @ 1 kHz tone
Audio Output Level: 400 mW
Supply Voltage: 7.2 V

MAIN Unit

Note

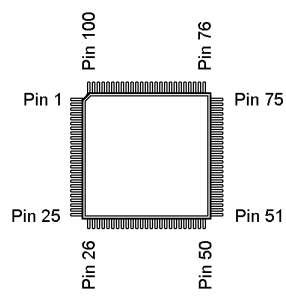
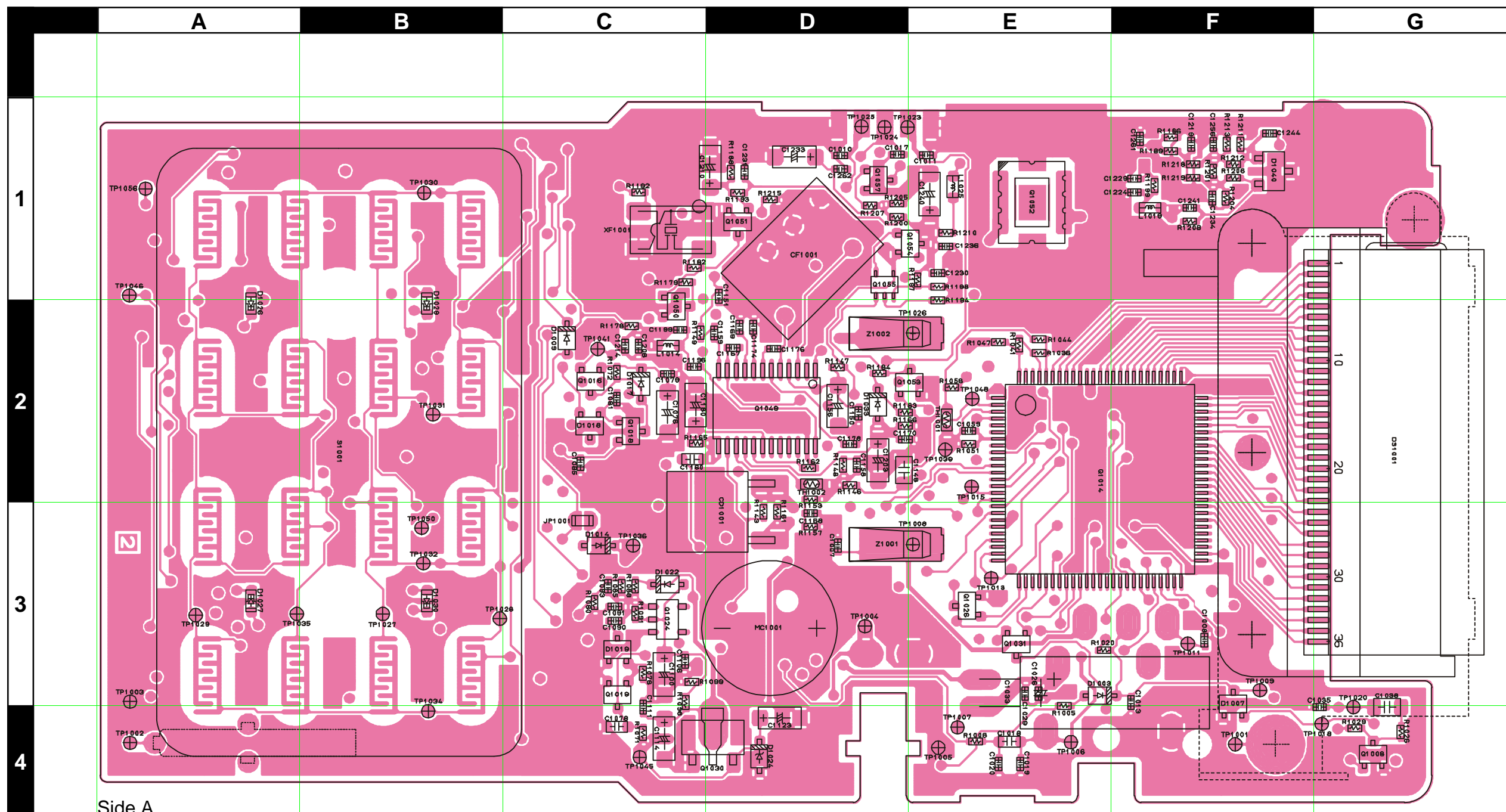

M38254M6 (Q1014)

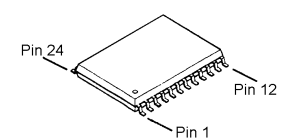

TK10931V (Q1049)

- | | | | | | | | | | | | |
|-----------------------|-----------------------------|-----------------------|-----------------------|-------------------------------|-----------------------------|-------------------|---------------------|-------------------|-----------------|-----------------|---------------------------------|
| | | | | | | | | | | | |
| 2SA1602A (MF) (Q1054) | 2SC4116GR (LG) (Q1016) | DTA143EU (23) (Q1018) | DTC124TU (05) (Q1019) | DTC143ZUA (123) (Q1008, 1031) | RT1N241M (N2) (Q1026, 1053) | S-80745SN (Q1024) | S-81235SGUP (Q1030) | UMW1 (W1) (Q1055) | 2SK2974 (Q1052) | HSM88WA (D1040) | MC2850 (A7) (D1007, 1018, 1019) |
| | 2SC4215 (QY) (Q1050) | | | | | | | | | | |
| | 2SC5226 (R22) (Q1051, 1057) | | | | | | | | | | |

MAIN Unit

Parts Layout

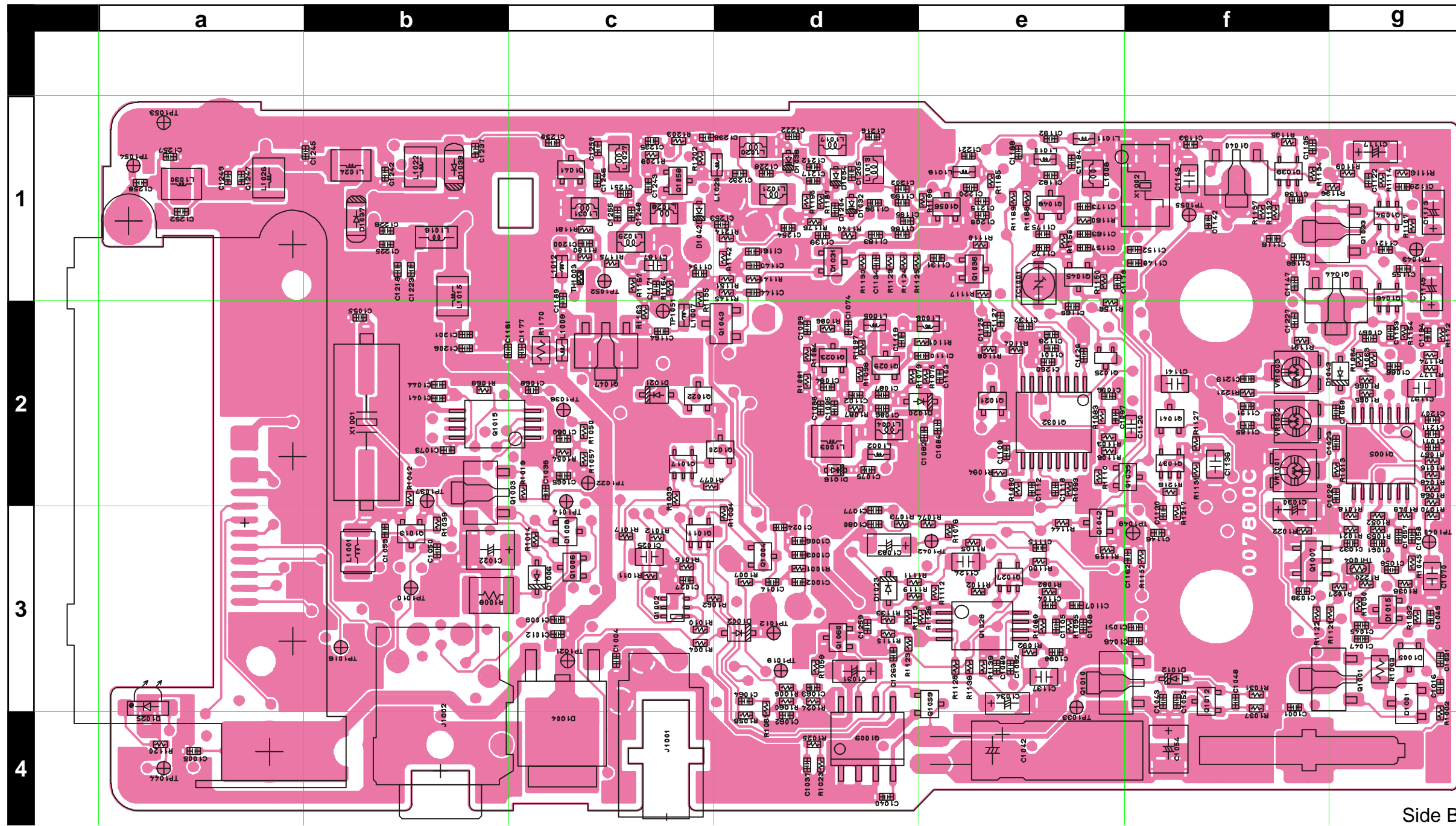

Side B

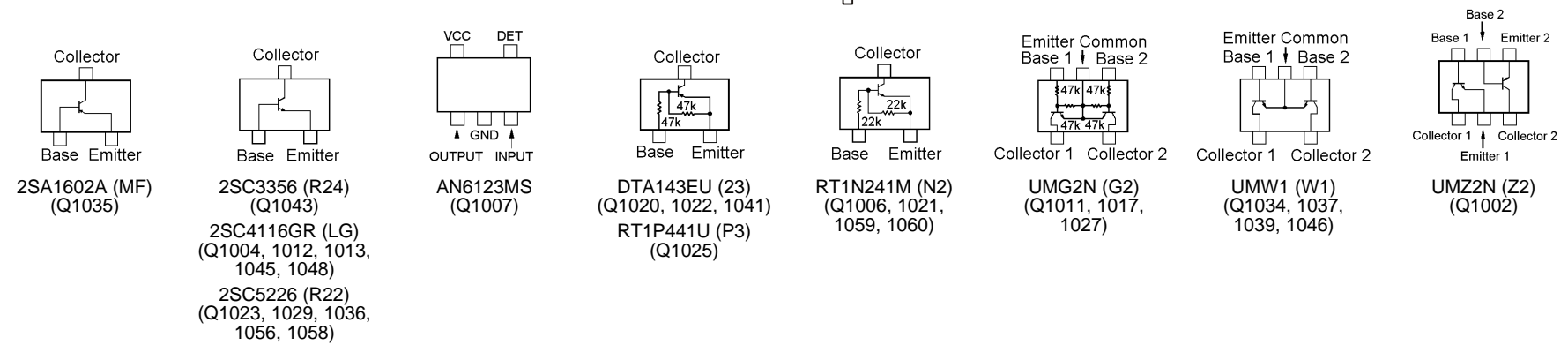
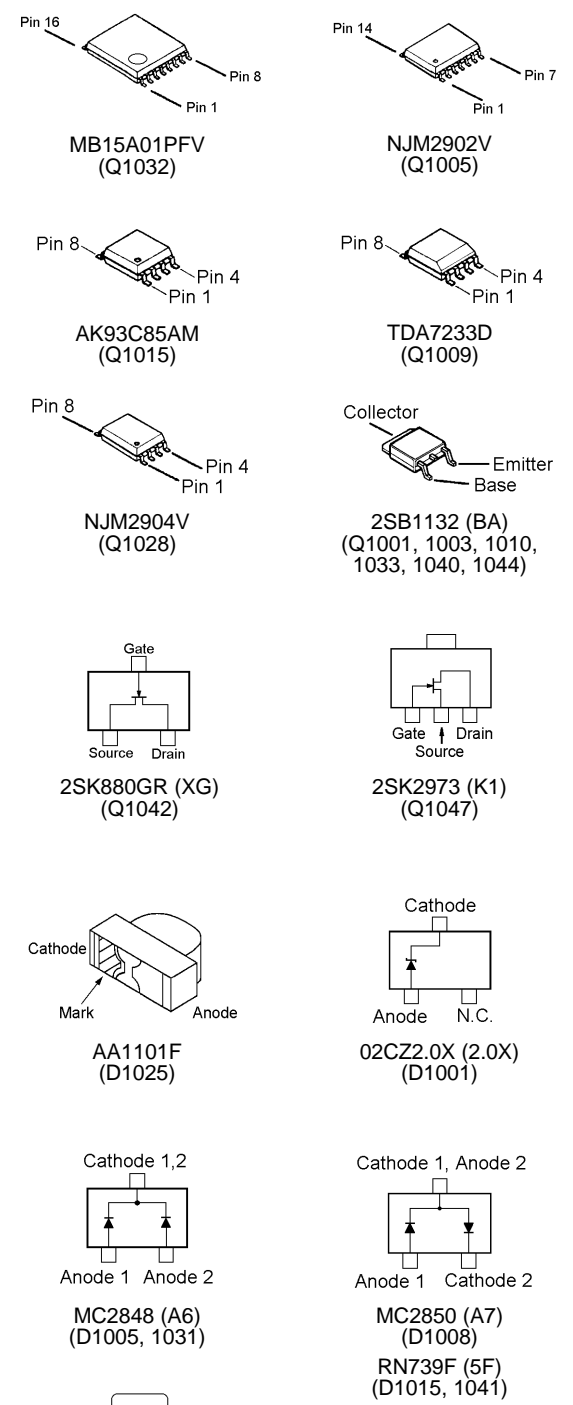

MAIN Unit

Parts List

REF.	DESCRIPTION	VALUE	V/W	TOL.	MFR'S DESIG	VXSTD P/N	VERS.	LOT.	SIDE	LAY ADR
PCB with Components		include HOLDER, LIGHT GUIDE, INTER CONNECTOR (LCD), TERMINAL PLATE R, BRACKET, INTER CONNECTOR (PCB)				CS1763001				
Printed Circuit Board						FR0078000		1		
C 1001	CHIP CAP.	0.001uF	50V	B	UMK105B102KW-F	K22178829		1	B	f3
C 1002	CHIP CAP.	0.001uF	50V	B	UMK105B102KW-F	K22178829		1	B	d3
C 1003	CHIP CAP.	0.001uF	50V	B	UMK105B102KW-F	K22178829		1	B	d3
C 1004	CHIP CAP.	0.001uF	50V	B	UMK105B102KW-F	K22178829		1	B	c3
C 1005	CHIP CAP.	0.01uF	16V	B	GRM36B103K16PT	K22128804		1	B	a4
C 1006	CHIP CAP.	0.1uF	10V	BJ	LMK105BJ104KV-F	K22108806		1	B	d3
C 1008	CHIP CAP.	0.001uF	50V	B	UMK105B102KW-F	K22178829		1	A	F3
C 1009	CHIP CAP.	0.01uF	16V	B	GRM36B103K16PT	K22128804		1	B	c3
C 1010	CHIP CAP.	0.001uF	50V	B	UMK105B102KW-F	K22178829		1	A	D1
C 1011	CHIP CAP.	0.001uF	50V	B	UMK105B102KW-F	K22178829		1	A	E1
C 1012	CHIP CAP.	0.001uF	50V	B	UMK105B102KW-F	K22178829		1	B	c3
C 1013	CHIP CAP.	220pF	25V	CH	TMK105CH221JW-F	K22148246		1	A	F3
C 1014	CHIP CAP.	0.1uF	10V	BJ	LMK105BJ104KV-F	K22108806		1	B	d3
C 1016	CHIP CAP.	0.001uF	50V	B	UMK105B102KW-F	K22178829		1	B	g3
C 1017	CHIP CAP.	0.001uF	50V	B	UMK105B102KW-F	K22178829		1	A	D1
C 1018	CHIP CAP.	0.1uF	16V	B	GRM39B104K16PT	K22124805		1	A	E4
C 1019	CHIP CAP.	0.001uF	50V	B	UMK105B102KW-F	K22178829		1	A	E4
C 1020	CHIP CAP.	0.1uF	10V	BJ	LMK105BJ104KV-F	K22108806		1	A	E4
C 1021	CHIP CAP.	0.001uF	50V	B	UMK105B102KW-F	K22178829		1	B	g3
C 1022	CHIP TA.CAP.	22uF	16V		TEMSVB21C226M-8R	K78120028		1	B	b3
C 1023	CHIP CAP.	0.1uF	10V	BJ	LMK105BJ104KV-F	K22108806		1	B	g2
C 1024	CHIP CAP.	0.1uF	10V	BJ	LMK105BJ104KV-F	K22108806		1	B	d3
C 1025	CHIP CAP.	1uF	10V	B	GRM40B105K10PT	K22100802		1	B	c3
C 1026	CHIP CAP.	0.001uF	50V	B	UMK105B102KW-F	K22178829		1	A	E3
C 1027	CHIP CAP.	0.1uF	10V	BJ	LMK105BJ104KV-F	K22108806		1	B	c3
C 1028	CHIP CAP.	0.001uF	50V	B	UMK105B102KW-F	K22178829		1	B	g2
C 1029	CHIP CAP.	100pF	50V	CH	UMK105CH101JW-F	K22178282		1	A	E3
C 1030	CHIP TA.CAP.	4.7uF	16V		TEMSVA1C475M-8R	K78120031		1	B	f3
C 1031	CHIP TA.CAP.	4.7uF	16V		TEMSVA1C475M-8R	K78120031		1	B	d3
C 1032	CHIP CAP.	0.1uF	10V	BJ	LMK105BJ104KV-F	K22108806		1	B	g3
C 1033	AL.ELECTRO.CAP.	220uF	10V		SMG1AVB221M 220UF	K40109027		1	A	E3
C 1034	CHIP TA.CAP.	4.7uF	16V		TEMSVA1C475M-8R	K78120031		1	B	e3
C 1036	CHIP CAP.	0.01uF	16V	B	GRM36B103K16PT	K22128804		1	B	c2
C 1037	CHIP CAP.	0.1uF	10V	BJ	LMK105BJ104KV-F	K22108806		1	B	d4
C 1038	CHIP CAP.	1uF	10V	B	GRM40B105K10PT	K22100802		1	A	G3
C 1040	CHIP CAP.	0.001uF	50V	B	UMK105B102KW-F	K22178829		1	B	d4
C 1041	CHIP CAP.	0.1uF	10V	BJ	LMK105BJ104KV-F	K22108806		1	B	b2
C 1042	AL.ELECTRO.CAP.	100uF	10V		UVR1A101MDA6 100UF	K40109028		1	B	e4
C 1043	CHIP CAP.	0.001uF	50V	B	UMK105B102KW-F	K22178829		1	B	f3
C 1044	CHIP CAP.	0.001uF	50V	B	UMK105B102KW-F	K22178829		1	B	b2
C 1045	CHIP CAP.	0.001uF	50V	B	UMK105B102KW-F	K22178829		1	B	g3
C 1046	CHIP CAP.	0.001uF	50V	B	UMK105B102KW-F	K22178829		1	B	f3
C 1047	CHIP CAP.	0.1uF	10V	BJ	LMK105BJ104KV-F	K22108806		1	B	g3
C 1048	CHIP CAP.	0.01uF	16V	B	GRM36B103K16PT	K22128804		1	B	f3
C 1049	CHIP CAP.	0.1uF	10V	BJ	LMK105BJ104KV-F	K22108806		1	B	g3
C 1050	CHIP CAP.	27pF	50V	CH	UMK105CH270JW-F	K22178268		1	B	b3
C 1051	CHIP CAP.	0.01uF	16V	B	GRM36B103K16PT	K22128804		1	B	f3
C 1052	CHIP CAP.	0.001uF	50V	B	UMK105B102KW-F	K22178829		1	B	f3
C 1053	CHIP CAP.	1pF	50V	CK	UMK105CK010CW-F	K22178248		1	B	b3
C 1055	CHIP CAP.	10pF	50V	CH	UMK105CH100DW-F	K22178258		1	B	b2
C 1056	CHIP CAP.	0.01uF	16V	B	GRM36B103K16PT	K22128804		1	B	g3
C 1057	CHIP CAP.	390pF	50V	B	UMK105B391KW-F	K22178824		1	B	g3
C 1058	CHIP CAP.	0.01uF	16V	B	GRM36B103K16PT	K22128804		1	B	g3
C 1059	CHIP CAP.	0.01uF	16V	B	GRM36B103K16PT	K22128804		1	A	E2
C 1060	CHIP CAP.	0.1uF	10V	BJ	LMK105BJ104KV-F	K22108806		1	B	c2
C 1061	CHIP CAP.	0.1uF	10V	BJ	LMK105BJ104KV-F	K22108806		1	B	g3
C 1062	CHIP CAP.	0.01uF	16V	B	GRM36B103K16PT	K22128804		1	B	d4
C 1063	CHIP CAP.	0.1uF	10V	BJ	LMK105BJ104KV-F	K22108806		1	B	d3
C 1064	CHIP CAP.	0.1uF	10V	BJ	LMK105BJ104KV-F	K22108806		1	B	d3
C 1065	CHIP CAP.	0.001uF	50V	B	UMK105B102KW-F	K22178829		1	B	c2
C 1066	CHIP CAP.	0.001uF	50V	B	UMK105B102KW-F	K22178829		1	B	g2
C 1067	CHIP CAP.	0.001uF	50V	B	UMK105B102KW-F	K22178829		1	B	g2
C 1068	CHIP CAP.	0.001uF	50V	B	UMK105B102KW-F	K22178829		1	B	c2

MAIN Unit

Parts List

REF.	DESCRIPTION	VALUE	V/W	TOL.	MFR'S DESIG	VXSTD P/N	VERS.	LOT.	SIDE	LAY ADR
C 1069	CHIP CAP.	180pF	25V	CH	TMK105CH181JW-F	K22148244		1	B	g2
C 1070	CHIP CAP.	1uF	10V	B	GRM40B105K10PT	K22100802		1	B	g3
C 1071	CHIP CAP.	0.001uF	50V	B	UMK105B102KW-F	K22178829		1	B	g2
C 1073	CHIP CAP.	0.1uF	10V	BJ	LMK105BJ104KV-F	K22108806		1	B	b2
C 1074	CHIP CAP.	0.01uF	16V	B	GRM36B103K16PT	K22128804		1	B	d2
C 1075	CHIP CAP.	100pF	50V	CH	UMK105CH101JW-F	K22178282		1	B	d2
C 1076	CHIP TA.CAP.	22uF	6.3V		TEMSVA0J226M-8R	K78080047		1	A	C2
C 1077	CHIP CAP.	0.047uF	10V	BJ	LMK105BJ473KV-F	K22108805		1	B	d3
C 1078	CHIP CAP.	0.22uF	10V	B	GRM39B224K10PT	K22104801		1	A	C4
C 1079	CHIP CAP.	0.001uF	50V	B	UMK105B102KW-F	K22178829		1	A	C2
C 1080	CHIP CAP.	0.047uF	10V	BJ	LMK105BJ473KV-F	K22108805		1	B	d3
C 1081	CHIP CAP.	0.001uF	50V	B	UMK105B102KW-F	K22178829		1	A	C2
C 1082	CHIP CAP.	0.022uF	16V	B	EMK105B223KW-F	K22128813		1	B	d2
C 1083	CHIP TA.CAP.	10uF	6.3V		TEMSVA0J106M-8R	K78080027		1	B	d3
C 1084	CHIP CAP.	0.022uF	16V	B	EMK105B223KW-F	K22128813		1	B	e2
C 1085	CHIP CAP.	0.001uF	50V	B	UMK105B102KW-F	K22178829		1	A	C2
C 1086	CHIP CAP.	0.022uF	16V	B	EMK105B223KW-F	K22128813		1	B	d2
C 1087	CHIP CAP.	0.022uF	16V	B	EMK105B223KW-F	K22128813		1	B	d2
C 1088	CHIP CAP.	10pF	50V	CH	UMK105CH100DW-F	K22178258		1	B	d2
C 1089	CHIP CAP.	0.001uF	50V	B	UMK105B102KW-F	K22178829		1	B	e3
C 1090	CHIP CAP.	0.1uF	10V	BJ	LMK105BJ104KV-F	K22108806		1	A	C3
C 1091	CHIP CAP.	0.001uF	50V	B	UMK105B102KW-F	K22178829		1	A	C3
C 1092	CHIP CAP.	0.1uF	10V	BJ	LMK105BJ104KV-F	K22108806		1	B	e3
C 1093	CHIP CAP.	0.001uF	50V	B	UMK105B102KW-F	K22178829		1	A	C3
C 1094	CHIP CAP.	33pF	50V	CH	UMK105CH330JW-F	K22178270		1	B	d2
C 1095	CHIP CAP.	15pF	50V	CH	UMK105CH150JW-F	K22178262		1	B	d2
C 1096	CHIP CAP.	0.001uF	50V	B	UMK105B102KW-F	K22178829		1	B	e2
C 1097	CHIP CAP.	0.001uF	50V	B	UMK105B102KW-F	K22178829		1	B	e2
C 1098	CHIP CAP.	0.001uF	50V	B	UMK105B102KW-F	K22178829		1	B	e3
C 1099	CHIP CAP.	0.001uF	50V	B	UMK105B102KW-F	K22178829		1	B	d2
C 1100	CHIP TA.CAP.	4.7uF	16V		TEMSVA1C475M-8R	K78120031		1	A	C3
C 1101	CHIP CAP.	0.001uF	50V	B	UMK105B102KW-F	K22178829		1	B	e2
C 1102	CHIP CAP.	3pF	50V	CJ	UMK105CJ030CW-F	K22178251		1	B	d2
C 1103	CHIP CAP.	0.001uF	50V	B	UMK105B102KW-F	K22178829		1	B	e2
C 1104	CHIP CAP.	0.0022uF	50V	B	UMK105B222KW-F	K22178833		1	B	e3
C 1105	CHIP CAP.	0.01uF	16V	B	GRM36B103K16PT	K22128804		1	B	e3
C 1106	CHIP CAP.	0.01uF	16V	B	GRM36B103K16PT	K22128804		1	A	C3
C 1107	CHIP CAP.	0.01uF	16V	B	GRM36B103K16PT	K22128804		1	B	e3
C 1109	CHIP CAP.	100pF	50V	CH	UMK105CH101JW-F	K22178282		1	B	e2
C 1110	CHIP CAP.	0.001uF	50V	B	UMK105B102KW-F	K22178829		1	B	d2
C 1111	CHIP CAP.	100pF	50V	CH	UMK105CH101JW-F	K22178282		1	A	C3
C 1112	CHIP CAP.	100pF	50V	CH	UMK105CH101JW-F	K22178282		1	B	e2
C 1113	CHIP TA.CAP.	4.7uF	16V		TEMSVA1C475M-8R	K78120031		1	B	g1
C 1114	CHIP TA.CAP.	4.7uF	20V		TEMSVA1D475M-8R	K78130048		1	A	C4
C 1115	CHIP CAP.	0.1uF	10V	BJ	LMK105BJ104KV-F	K22108806		1	B	e3
C 1116	CHIP CAP.	0.001uF	50V	B	UMK105B102KW-F	K22178829		1	B	f1
C 1117	CHIP TA.CAP.	22uF	4V		TEMSVA0G226M-8R	K78060023		1	B	g1
C 1118	CHIP CAP.	100pF	50V	CH	UMK105CH101JW-F	K22178282		1	B	e2
C 1119	CHIP CAP.	7pF	50V	CH	UMK105CH070DW-F	K22178255		1	B	d2
C 1120	CHIP CAP.	0.22uF	10V	B	GRM39B224K10PT	K22104801		1	B	f2
C 1121	CHIP CAP.	0.001uF	50V	B	UMK105B102KW-F	K22178829		1	B	g1
C 1122	CHIP CAP.	0.001uF	50V	B	UMK105B102KW-F	K22178829		1	B	g1
C 1123	CHIP TA.CAP.	33uF	4V		TEMSVA0G336M-8R	K78060036		1	A	D4
C 1124	CHIP CAP.	1uF	10V	B	GRM40B105K10PT	K22100802		1	B	e3
C 1125	CHIP CAP.	0.001uF	50V	B	UMK105B102KW-F	K22178829		1	B	e2
C 1127	CHIP CAP.	10pF	50V	CH	UMK105CH100DW-F	K22178258		1	B	e2
C 1128	CHIP CAP.	0.01uF	16V	B	GRM36B103K16PT	K22128804		1	B	e2
C 1129	CHIP CAP.	0.001uF	50V	B	UMK105B102KW-F	K22178829		1	B	g1
C 1130	CHIP CAP.	0.001uF	50V	B	UMK105B102KW-F	K22178829		1	B	f3
C 1131	CHIP CAP.	5pF	50V	CH	UMK105CH050CW-F	K22178253		1	B	e1
C 1133	CHIP CAP.	0.001uF	50V	B	UMK105B102KW-F	K22178829		1	B	f1
C 1134	CHIP CAP.	10pF	50V	CH	UMK105CH100DW-F	K22178258		1	B	d1
C 1135	CHIP CAP.	0.01uF	16V	B	GRM36B103K16PT	K22128804		1	B	f1
C 1136	CHIP CAP.	1uF	10V	B	GRM40B105K10PT	K22100802		1	B	f2
C 1137	CHIP CAP.	1uF	10V	B	GRM40B105K10PT	K22100802		1	B	e3
C 1138	CHIP CAP.	0.1uF	10V	BJ	LMK105BJ104KV-F	K22108806		1	B	f1
C 1139	CHIP CAP.	0.001uF	50V	B	UMK105B102KW-F	K22178829		1	B	d1

MAIN Unit

Parts List

REF.	DESCRIPTION	VALUE	V/W	TOL.	MFR'S DESIG	VXSTD P/N	VERS.	LOT.	SIDE	LAY ADR
C 1140	CHIP CAP.	0.001uF	50V	B	UMK105B102KW-F	K22178829		1	B	d1
C 1141	CHIP CAP.	1uF	10V	B	GRM40B105K10PT	K22100802		1	B	f2
C 1142	CHIP CAP.	0.001uF	50V	B	UMK105B102KW-F	K22178829		1	B	f1
C 1143	CHIP CAP.	1uF	10V	B	GRM40B105K10PT	K22100802		1	B	f1
C 1144	CHIP CAP.	12pF	50V	CH	UMK105CH120JW-F	K22178260		1	B	d1
C 1145	CHIP TA.CAP.	10uF	6.3V		TEMSVA0J106M-8R	K78080027		1	B	g1
C 1146	CHIP CAP.	0.001uF	50V	B	UMK105B102KW-F	K22178829		1	B	f3
C 1147	CHIP CAP.	0.001uF	50V	B	UMK105B102KW-F	K22178829		1	B	f1
C 1148	CHIP CAP.	0.47uF	25V	B	GRM40B474K25PT	K22140824		1	A	D2
C 1149	CHIP CAP.	15pF	50V	CH	UMK105CH150JW-F	K22178262		1	B	f1
C 1150	CHIP CAP.	0.001uF	50V	B	UMK105B102KW-F	K22178829		1	A	D2
C 1151	CHIP CAP.	0.0033uF	50V	B	UMK105B332KW-F	K22178835		1	A	D1
C 1153	CHIP CAP.	0.001uF	50V	B	UMK105B102KW-F	K22178829		1	B	g2
C 1154	CHIP CAP.	0.001uF	50V	B	UMK105B102KW-F	K22178829		1	B	c1
C 1155	CHIP CAP.	0.001uF	50V	B	UMK105B102KW-F	K22178829		1	B	g1
C 1156	CHIP TA.CAP.	10uF	6.3V		TEMSVA0J106M-8R	K78080027		1	A	D2
C 1157	CHIP CAP.	47pF	50V	CH	UMK105CH470JW-F	K22178274		1	B	e1
C 1158	CHIP CAP.	0.001uF	50V	B	UMK105B102KW-F	K22178829		1	A	D2
C 1159	CHIP CAP.	0.01uF	16V	B	GRM36B103K16PT	K22128804		1	A	D2
C 1160	CHIP CAP.	1uF	10V	F	GRM39F105Z10PT	K22105001		1	A	C2
C 1161	CHIP CAP.	0.01uF	16V	B	GRM36B103K16PT	K22128804		1	B	d1
C 1162	CHIP CAP.	0.001uF	50V	B	UMK105B102KW-F	K22178829		1	B	e3
C 1164	CHIP CAP.	15pF	50V	CH	UMK105CH150JW-F	K22178262		1	B	c2
C 1165	CHIP CAP.	0.001uF	50V	B	UMK105B102KW-F	K22178829		1	B	e2
C 1166	CHIP CAP.	0.001uF	50V	B	UMK105B102KW-F	K22178829		1	B	f1
C 1167	CHIP CAP.	68pF	50V	CH	UMK105CH680JW-F	K22178278		1	A	D2
C 1168	CHIP CAP.	0.1uF	10V	BJ	LMK105BJ104KV-F	K22108806		1	A	D3
C 1169	CHIP CAP.	0.1uF	10V	BJ	LMK105BJ104KV-F	K22108806		1	A	D2
C 1171	CHIP CAP.	0.001uF	50V	B	UMK105B102KW-F	K22178829		1	B	c1
C 1172	CHIP CAP.	470pF	50V	B	UMK105B471KW-F	K22178825		1	B	e1
C 1173	CHIP CAP.	47pF	50V	CH	UMK105CH470JW-F	K22178274		1	B	e1
C 1174	CHIP CAP.	0.1uF	10V	BJ	LMK105BJ104KV-F	K22108806		1	A	D2
C 1175	CHIP CAP.	39pF	50V	CH	UMK105CH390JW-F	K22178272		1	B	e1
C 1176	CHIP CAP.	0.0047uF	25V	B	TMK105B472KW-F	K22148831		1	A	D2
C 1177	CHIP CAP.	0.001uF	50V	B	UMK105B102KW-F	K22178829		1	B	c2
C 1178	CHIP CAP.	0.1uF	10V	BJ	LMK105BJ104KV-F	K22108806		1	A	D2
C 1180	CHIP TA.CAP.	0.22uF	20V		TEMSVA21D224M-8R	K78130022		1	A	C2
C 1181	CHIP CAP.	0.01uF	16V	B	GRM36B103K16PT	K22128804		1	B	b2
C 1182	CHIP CAP.	39pF	50V	CH	UMK105CH390JW-F	K22178272		1	B	e1
C 1183	CHIP CAP.	0.001uF	50V	B	UMK105B102KW-F	K22178829		1	B	d1
C 1184	CHIP CAP.	12pF	50V	CH	UMK105CH120JW-F	K22178260		1	B	e1
C 1185	CHIP CAP.	0.1uF	10V	BJ	LMK105BJ104KV-F	K22108806		1	B	f2
C 1186	CHIP CAP.	0.5pF	50V	CK	UMK105CK0R5CW-F	K22178247		1	B	d1
C 1187	CHIP CAP.	1uF	10V	F	GRM39F105Z10PT	K22105001		1	B	c1
C 1188	CHIP CAP.	0.001uF	50V	B	UMK105B102KW-F	K22178829		1	B	e1
C 1189	CHIP CAP.	68pF	50V	CH	UMK105CH680JW-F	K22178278		1	B	c1
C 1191	CHIP CAP.	0.001uF	50V	B	UMK105B102KW-F	K22178829		1	B	f2
C 1192	CHIP CAP.	47pF	50V	CH	UMK105CH470JW-F	K22178274		1	B	e1
C 1193	CHIP CAP.	0.5pF	50V	CK	UMK105CK0R5CW-F	K22178247		1	B	d1
C 1194	CHIP CAP.	0.001uF	50V	B	UMK105B102KW-F	K22178829		1	B	g2
C 1195	CHIP CAP.	1pF	50V	CK	UMK105CK010CW-F	K22178248		1	B	d1
C 1196	CHIP CAP.	0.01uF	16V	B	GRM36B103K16PT	K22128804		1	A	C2
C 1197	CHIP CAP.	0.47uF	25V	B	GRM40B474K25PT	K22140824		1	B	g2
C 1198	CHIP CAP.	220pF	25V	CH	TMK105CH221JW-F	K22148246		1	B	d1
C 1199	CHIP CAP.	39pF	50V	CH	UMK105CH390JW-F	K22178272		1	A	C2
C 1200	CHIP CAP.	0.001uF	50V	B	UMK105B102KW-F	K22178829		1	B	c1
C 1201	CHIP CAP.	0.001uF	50V	B	UMK105B102KW-F	K22178829		1	B	b2
C 1202	CHIP CAP.	0.5pF	50V	CK	UMK105CK0R5CW-F	K22178247		1	B	d1
C 1203	CHIP TA.CAP.	2.2uF	16V		TEMSVA1C225M-8R	K78120015		1	A	D2
C 1204	CHIP CAP.	220pF	25V	CH	TMK105CH221JW-F	K22148246		1	B	d1
C 1205	CHIP CAP.	1pF	50V	CK	UMK105CK010CW-F	K22178248		1	B	d1
C 1206	CHIP CAP.	0.01uF	16V	B	GRM36B103K16PT	K22128804		1	B	b2
C 1208	CHIP CAP.	0.0047uF	25V	B	TMK105B472KW-F	K22148831		1	A	C2
C 1209	CHIP CAP.	0.0047uF	25V	B	TMK105B472KW-F	K22148831		1	B	e1
C 1211	CHIP CAP.	0.001uF	50V	B	UMK105B102KW-F	K22178829		1	B	g2
C 1212	CHIP CAP.	220pF	25V	CH	TMK105CH221JW-F	K22148246		1	B	d1
C 1213	CHIP CAP.	0.001uF	50V	B	UMK105B102KW-F	K22178829		1	B	f2

MAIN Unit

Parts List

REF.	DESCRIPTION	VALUE	V/W	TOL.	MFR'S DESIG	VXSTD P/N	VERS.	LOT.	SIDE	LAY ADR
C 1214	CHIP CAP.	0.01uF	16V	B	GRM36B103K16PT	K22128804		1	A	C2
C 1215	CHIP CAP.	0.01uF	16V	B	GRM36B103K16PT	K22128804		1	B	e1
C 1216	CHIP CAP.	2pF	50V	CK	UMK105CK020CW-F	K22178250		1	B	d1
C 1217	CHIP CAP.	220pF	25V	CH	TMK105CH221JW-F	K22148246		1	B	d1
C 1218	CHIP CAP.	33pF	50V	CH	UMK105CH330JW-F	K22178270		1	B	b1
C 1219	CHIP CAP.	0.001uF	50V	B	UMK105B102KW-F	K22178829		1	A	F1
C 1220	CHIP CAP.	0.001uF	50V	B	UMK105B102KW-F	K22178829		1	B	e1
C 1221	CHIP CAP.	39pF	50V	CH	UMK105CH390JW-F	K22178272		1	B	e1
C 1222	CHIP CAP.	1pF	50V	CK	UMK105CK010CW-F	K22178248		1	B	d1
C 1223	CHIP CAP.	18pF	50V	CH	UMK105CH180JW-F	K22178264		1	B	b1
C 1224	CHIP CAP.	0.001uF	50V	B	UMK105B102KW-F	K22178829		1	A	F1
C 1225	CHIP CAP.	12pF	50V	CH	UMK105CH120JW-F	K22178260		1	B	b1
C 1226	CHIP CAP.	33pF	50V	CH	UMK105CH330JW-F	K22178270		1	B	b1
C 1228	CHIP CAP.	220pF	25V	CH	TMK105CH221JW-F	K22148246		1	B	d1
C 1229	CHIP CAP.	0.001uF	50V	B	UMK105B102KW-F	K22178829		1	A	F1
C 1230	CHIP CAP.	0.01uF	16V	B	GRM36B103K16PT	K22128804		1	A	E1
C 1231	CHIP CAP.	0.01uF	16V	B	GRM36B103K16PT	K22128804		1	A	D1
C 1232	CHIP CAP.	10pF	50V	CH	UMK105CH100DW-F	K22178258		1	B	d1
C 1234	CHIP CAP.	0.1uF	10V	BJ	LMK105BJ104KV-F	K22108806		1	A	F1
C 1235	CHIP CAP.	0.001uF	50V	B	UMK105B102KW-F	K22178829		1	B	c1
C 1236	CHIP CAP.	0.001uF	50V	B	UMK105B102KW-F	K22178829		1	A	E1
C 1237	CHIP CAP.	12pF	50V	CH	UMK105CH120JW-F	K22178260		1	B	b1
C 1238	CHIP CAP.	0.001uF	50V	B	UMK105B102KW-F	K22178829		1	B	c1
C 1239	CHIP CAP.	47pF	50V	CH	UMK105CH470JW-F	K22178274		1	B	c1
C 1241	CHIP CAP.	0.5pF	50V	CK	UMK105CK0R5CW-F	K22178247		1	A	F1
C 1242	CHIP CAP.	39pF	50V	CH	UMK105CH390JW-F	K22178272		1	B	b1
C 1243	CHIP CAP.	22pF	50V	CH	UMK105CH220JW-F	K22178266		1	B	c1
C 1244	CHIP CAP.	0.5pF	50V	CK	UMK105CK0R5CW-F	K22178247		1	A	F1
C 1245	CHIP CAP.	33pF	50V	CH	UMK105CH330JW-F	K22178270		1	B	a1
C 1246	CHIP CAP.	0.001uF	50V	B	UMK105B102KW-F	K22178829		1	B	c1
C 1247	CHIP CAP.	5pF	50V	CH	UMK105CH050CW-F	K22178253		1	B	a1
C 1248	CHIP CAP.	15pF	50V	CH	UMK105CH150JW-F	K22178262		1	B	c1
C 1249	CHIP CAP.	27pF	50V	CH	UMK105CH270JW-F	K22178268		1	B	a1
C 1250	CHIP CAP.	22pF	50V	CH	UMK105CH220JW-F	K22178266		1	B	c1
C 1251	CHIP CAP.	22pF	50V	CH	UMK105CH220JW-F	K22178266		1	B	c1
C 1252	CHIP CAP.	5pF	50V	CH	UMK105CH050CW-F	K22178253		1	B	a1
C 1253	CHIP CAP.	27pF	50V	CH	UMK105CH270JW-F	K22178268		1	B	d1
C 1254	CHIP CAP.	0.001uF	50V	B	UMK105B102KW-F	K22178829		1	B	d1
C 1255	CHIP CAP.	68pF	50V	CH	UMK105CH680JW-F	K22178278		1	B	c1
C 1256	CHIP CAP.	0.1uF	10V	BJ	LMK105BJ104KV-F	K22108806		1	A	F1
C 1257	CHIP CAP.	15pF	50V	CH	UMK105CH150JW-F	K22178262		1	B	a1
C 1258	CHIP CAP.	0.001uF	50V	B	UMK105B102KW-F	K22178829		1	B	a1
C 1259	CHIP CAP.	0.047uF	10V	BJ	LMK105BJ473KV-F	K22108805		1	B	d3
C 1260	CHIP CAP.	0.001uF	50V	B	UMK105B102KW-F	K22178829		1	B	e2
C 1261	CHIP CAP.	0.001uF	50V	B	UMK105B102KW-F	K22178829		1	A	F1
C 1262	CHIP CAP.	0.1uF	10V	BJ	LMK105BJ104KV-F	K22108806		1	A	D1
CD1001	CERAMIC DISC				CDBM450C24T	H7901060		1	A	D3
CF1001	CERAMIC FILTER				ALFYM450F=K	H3900531		1	A	D2
D 1001	DIODE				02CZ2.0X TE85R	G2070124		1	B	g3
D 1002	DIODE				BAS316	G2070716		1	B	d3
D 1003	DIODE				BAS316	G2070716		1	A	E3
D 1004	DIODE				SB40W03T-TL	G2070370		1	B	c4
D 1005	DIODE				MC2848-T11-1	G2070694		1	B	g3
D 1006	DIODE				BAS316	G2070716		1	B	c3
D 1007	DIODE				MC2850-T11-1	G2070704		1	A	F3
D 1008	DIODE				MC2850-T11-1	G2070704		1	B	c3
D 1009	DIODE				BAS316	G2070716		1	A	C2
D 1012	DIODE				RD6.8UMB2-T1B	G2070438		1	B	f3
D 1014	DIODE				BAS316	G2070716		1	A	C3
D 1015	DIODE				RN739F T106	G2070626		1	B	g3
D 1016	DIODE				HVC350B-TRF	G2070596		1	B	d2
D 1017	DIODE				BAS316	G2070716		1	A	C2
D 1018	DIODE				MC2850-T11-1	G2070704		1	A	C2
D 1019	DIODE				MC2850-T11-1	G2070704		1	A	C3
D 1020	DIODE				HSU277TRF	G2070118		1	B	d2
D 1021	DIODE				BAS316	G2070716		1	B	c2
D 1022	DIODE				BAS316	G2070716		1	A	C3

MAIN Unit

Parts List

REF.	DESCRIPTION	VALUE	V/W	TOL.	MFR'S DESIG	VXSTD P/N	VERS.	LOT.	SIDE	LAY ADR
D 1023	DIODE				BAS316	G2070716		1	B	d3
D 1024	DIODE				HZU4ALL-TR	G2070428		1	A	D4
D 1025	LED				AA1101F-TR	G2070658		1	B	a3
D 1026	LED				AA1111C-TR	G2070660		1	A	A2
D 1027	LED				AA1111C-TR	G2070660		1	A	A3
D 1029	LED				AA1111C-TR	G2070660		1	A	B2
D 1030	LED				AA1111C-TR	G2070660		1	A	B3
D 1031	DIODE				MC2848-T11-1	G2070694		1	B	d1
D 1032	DIODE				HVC350B-TRF	G2070596		1	B	d1
D 1033	DIODE				BAS316	G2070716		1	A	D2
D 1034	DIODE				HVC350B-TRF	G2070596		1	B	d1
D 1036	DIODE				HVC350B-TRF	G2070596		1	B	d1
D 1037	DIODE				RLS135 TE-11	G2070128		1	B	b1
D 1039	DIODE				RLS135 TE-11	G2070128		1	B	b1
D 1040	DIODE				HSM88WA TR	G2070168		1	A	F1
D 1041	DIODE				RN739F T106	G2070626		1	B	c1
D 1042	DIODE				HVC350B-TRF	G2070596		1	B	c1
D 1043	DIODE				BAS316	G2070716		1	B	g2
DS1001	LCD				HT-3633-TFZWH	G6090139		1	A	G2
J 1001	CONNECTOR				HEC3604-010110	P0091263		1	B	c4
J 1002	CONNECTOR				HSJ1594-010015	P1091022		1	B	b4
L 1001	M.RFC	180uH			FLC32T-181J	L1690230		1	B	b3
L 1002	M.RFC	4.7uH			LK1608 4R7K-T	L1690688		1	B	d2
L 1003	COIL				E2 0.3-1.7-8T-L	L0022376		1	B	d2
L 1004	CHIP COIL	0.039uH			LQN21A39NJ04	L1690616		1	B	d2
L 1005	M.RFC	0.1uH			HK1608 R10J-T	L1690528		1	B	d2
L 1006	M.RFC	0.1uH			HK1608 R10J-T	L1690528		1	B	e2
L 1007	M.RFC	0.068uH			HK1608 68NJ-T	L1690526		1	B	c2
L 1008	CHIP COIL	0.033uH			LQN21A33NJ04	L1690615		1	B	e1
L 1009	M.RFC	0.082uH			HK1608 82NJ-T	L1690527		1	B	c2
L 1010	M.RFC	0.47uH			LK1608 R47K-T	L1690414		1	B	e1
L 1011	M.RFC	0.033uH			HK1608 33NJ-T	L1690522		1	B	e1
L 1012	M.RFC	0.022uH			HK1608 22NJ-T	L1690520		1	B	c1
L 1013	CHIP COIL	0.1uH			LQN21AR10J04	L1690620		1	B	d1
L 1014	M.RFC	0.56uH			LK1608 R56K-T	L1690415		1	A	C2
L 1015	COIL				E2 0.3-1.7-8T-L	L0022376		1	B	b1
L 1016	COIL				E2 0.28-1.0-6.5T-R-S	L0022598		1	B	b1
L 1017	CHIP COIL	0.1uH			LQN21AR10J04	L1690620		1	B	d1
L 1018	M.RFC	0.56uH			LK1608 R56K-T	L1690415		1	B	e1
L 1019	M.RFC	4.7uH			LK1608 4R7K-T	L1690688		1	A	F1
L 1020	CHIP COIL	0.033uH			LQN21A33NJ04	L1690615		1	B	d1
L 1021	CHIP COIL	0.068uH			LQN21A68NJ04	L1690605		1	B	d1
L 1022	COIL				E2 0.3-1.7-8T-L	L0022376		1	B	b1
L 1023	M.RFC	6.8uH			LK1608 6R8K-T	L1690632		1	B	c1
L 1024	COIL				E2 0.3-1.7-8T-L	L0022376		1	B	b1
L 1025	M.RFC	4.7uH			LK1608 4R7K-T	L1690688		1	A	E1
L 1026	COIL				E2 0.3-1.7-8T-L	L0022376		1	B	a1
L 1027	CHIP COIL	0.12uH			LQN21AR12J04	L1690621		1	B	c1
L 1028	CHIP COIL	0.068uH			LQN21A68NJ04	L1690605		1	B	c1
L 1029	CHIP COIL	0.039uH			LQN21A39NJ04	L1690616		1	B	c1
L 1030	COIL				E2 0.3-1.7-8T-L	L0022376		1	B	a1
L 1031	CHIP COIL	0.068uH			LQN21A68NJ04	L1690605		1	B	c1
MC1001	MIC. ELEMENT				EM-100PT	M3290029		1	A	D3
Q 1001	TRANSISTOR				2SB1132 T100 Q	G3211327Q		1	B	f3
Q 1002	TRANSISTOR				UMZ2N TR	G3070117		1	B	c3
Q 1003	TRANSISTOR				2SB1132 T100 Q	G3211327Q		1	B	b2
Q 1004	TRANSISTOR				2SC4116GR TE85R	G3341167G		1	B	d3
Q 1005	IC				NJM2902V-TE1	G1091679		1	B	g2
Q 1006	TRANSISTOR				RT1N241M-T11-1	G3070249		1	B	c3
Q 1007	IC				AN6123MS-TXL	G1093114		1	B	f3
Q 1008	TRANSISTOR				DTC143ZUA T106	G3070188		1	A	G4
Q 1009	IC				TDA7233D-TR	G1091112		1	B	d4
Q 1010	TRANSISTOR				2SB1132 T100 Q	G3211327Q		1	B	e3
Q 1011	TRANSISTOR				UMG2N TR	G3070088		1	B	c3
Q 1012	TRANSISTOR				2SC4116GR TE85R	G3341167G		1	B	f3
Q 1013	TRANSISTOR				2SC4116GR TE85R	G3341167G		1	B	b3
Q 1014	IC				M38254M6-357GP	G1093587		1	A	E2

MAIN Unit

Parts List

REF.	DESCRIPTION	VALUE		TOL.	MFR'S DESIG	VXSTD P/N	VERS.	LOT.	SIDE	LAYADR
Q 1015	IC				AK93C85AM E-1	G1092706		1	B	b2
Q 1016	TRANSISTOR				2SC4116GR TE85R	G3341167G		1	A	C2
Q 1017	TRANSISTOR				UMG2N TR	G3070088		1	B	c2
Q 1018	TRANSISTOR				DTA143EU T106	G3070110		1	A	C2
Q 1019	TRANSISTOR				DTC124TU T106	G3070065		1	A	C3
Q 1020	TRANSISTOR				DTA143EU T106	G3070110		1	B	d2
Q 1021	TRANSISTOR				RT1N241M-T11-1	G3070249		1	B	e2
Q 1022	TRANSISTOR				DTA143EU T106	G3070110		1	B	c2
Q 1023	TRANSISTOR				2SC5226-5-TL	G3352268E		1	B	d2
Q 1024	IC				S-80745SN-D9-T1	G1093146		1	A	C3
Q 1025	TRANSISTOR				RT1P441U-T11-1	G3070248		1	B	e2
Q 1026	TRANSISTOR				RT1N241M-T11-1	G3070249		1	A	E3
Q 1027	TRANSISTOR				UMG2N TR	G3070088		1	B	e3
Q 1028	IC				NJM2904V-TE1	G1091677		1	B	e3
Q 1029	TRANSISTOR				2SC5226-5-TL	G3352268E		1	B	d2
Q 1030	IC				S-81235SGUP-DQI-T1	G1093026		1	A	D4
Q 1031	TRANSISTOR				DTC143ZUA T106	G3070188		1	A	E3
Q 1032	IC				MB15A01PFV1-G-BND-EF	G1092545		1	B	e2
Q 1033	TRANSISTOR				2SB1132 T100 Q	G3211327Q		1	B	f1
Q 1034	TRANSISTOR				UMW1 TR	G3070078		1	B	g1
Q 1035	TRANSISTOR				2SA1602A-T11-1F	G3116028F		1	B	e2
Q 1036	TRANSISTOR				2SC5226-5-TL	G3352268E		1	B	e1
Q 1037	TRANSISTOR				UMW1 TR	G3070078		1	B	f2
Q 1039	TRANSISTOR				UMW1 TR	G3070078		1	B	f1
Q 1040	TRANSISTOR				2SB1132 T100 Q	G3211327Q		1	B	f1
Q 1041	TRANSISTOR				DTA143EU T106	G3070110		1	B	f2
Q 1042	FET				2SK880GR TE85R	G3808807G		1	B	e3
Q 1043	TRANSISTOR				2SC3356-T2B R25	G3333567E		1	B	d2
Q 1044	TRANSISTOR				2SB1132 T100 Q	G3211327Q		1	B	g2
Q 1045	TRANSISTOR				2SC4116GR TE85R	G3341167G		1	B	e1
Q 1046	TRANSISTOR				UMW1 TR	G3070078		1	B	g1
Q 1047	FET				2SK2973-T13	G3829738		1	B	c2
Q 1048	TRANSISTOR				2SC4116GR TE85R	G3341167G		1	B	e1
Q 1049	IC				TK10931VT1	G1093013		1	A	D2
Q 1050	TRANSISTOR				2SC4215Y TE85R	G3342157Y		1	A	C2
Q 1051	TRANSISTOR				2SC5226-5-TL	G3352268E		1	A	D1
Q 1052	FET				2SK2974-T11	G3829747		1	A	E1
Q 1053	TRANSISTOR				RT1N241M-T11-1	G3070249		1	A	D2
Q 1054	TRANSISTOR				2SA1602A-T11-1F	G3116028F		1	A	D1
Q 1055	TRANSISTOR				UMW1 TR	G3070078		1	A	D1
Q 1056	TRANSISTOR				2SC5226-5-TL	G3352268E		1	B	e1
Q 1057	TRANSISTOR				2SC5226-5-TL	G3352268E		1	A	D1
Q 1058	TRANSISTOR				2SC5226-5-TL	G3352268E		1	B	c1
Q 1059	TRANSISTOR				RT1N241M-T11-1	G3070249		1	B	e3
Q 1060	TRANSISTOR				RT1N241M-T11-1	G3070249		1	B	d3
R 1001	CHIP RES.	2.2k	1/16W	5%	RMC1/16S 222JTH	J24189029		1	B	d3
R 1002	CHIP RES.	2.2k	1/16W	5%	RMC1/16S 222JTH	J24189029		1	B	g3
R 1003	CHIP RES.	22	1/10W	5%	RMC1/10T 220J	J24205220		1	B	g3
R 1004	CHIP RES.	680	1/16W	5%	RMC1/16S 681JTH	J24189023		1	B	c3
R 1005	CHIP RES.	22k	1/16W	5%	RMC1/16S 223JTH	J24189041		1	A	E3
R 1006	CHIP RES.	100	1/16W	5%	RMC1/16S 101JTH	J24189013		1	B	d3
R 1007	CHIP RES.	2.2k	1/16W	5%	RMC1/16S 222JTH	J24189029		1	B	d3
R 1008	CHIP RES.	10k	1/16W	5%	RMC1/16S 103JTH	J24189037		1	A	E4
R 1009	CHIP RES.	150	1/4W	5%	RMC1/4 151JATP	J24245151		1	B	b3
R 1010	CHIP RES.	8.2k	1/16W	5%	RMC1/16S 822JTH	J24189036		1	B	c3
R 1011	CHIP RES.	6.8k	1/16W	5%	RMC1/16S 682JTH	J24189035		1	B	c3
R 1012	CHIP RES.	100k	1/16W	5%	RMC1/16S 104JTH	J24189049		1	B	c3
R 1013	CHIP RES.	10k	1/16W	5%	RMC1/16S 103JTH	J24189037		1	B	g2
R 1014	CHIP RES.	10k	1/16W	5%	RMC1/16S 103JTH	J24189037		1	B	c3
R 1015	CHIP RES.	47k	1/16W	5%	RMC1/16S 473JTH	J24189045		1	B	c3
R 1016	CHIP RES.	47k	1/16W	5%	RMC1/16S 473JTH	J24189045		1	B	g2
R 1017	CHIP RES.	2.7k	1/16W	5%	RMC1/16S 272JTH	J24189030		1	B	c3
R 1018	CHIP RES.	68k	1/16W	5%	RMC1/16S 683JTH	J24189047		1	B	g3
R 1019	CHIP RES.	18	1/16W	5%	RMC1/16S 180JTH	J24189004		1	B	c2
R 1020	CHIP RES.	4.7k	1/16W	5%	RMC1/16S 472JTH	J24189033		1	A	E3
R 1021	CHIP RES.	10k	1/16W	5%	RMC1/16S 103JTH	J24189037		1	B	g3
R 1022	CHIP RES.	1M	1/16W	5%	RMC1/16S 105JTH	J24189061		1	B	f3

MAIN Unit

Parts List

REF.	DESCRIPTION	VALUE	V/W	TOL.	MFR'S DESIG	VXSTD P/N	VERS.	LOT.	SIDE	LAY ADR
R 1024	CHIP RES.	470	1/16W	5%	RMC1/16S 471JTH	J24189021		1	B	d3
R 1025	CHIP RES.	10	1/16W	5%	RMC1/16S 100JTH	J24189001		1	B	d4
R 1026	CHIP RES.	4.7k	1/16W	5%	RMC1/16S 472JTH	J24189033		1	A	G4
R 1027	CHIP RES.	10k	1/16W	5%	RMC1/16S 103JTH	J24189037		1	B	g3
R 1029	CHIP RES.	5.6k	1/16W	5%	RMC1/16S 562JTH	J24189034		1	A	G4
R 1030	CHIP RES.	1.2k	1/16W	5%	RMC1/16S 122JTH	J24189026		1	B	g3
R 1031	CHIP RES.	100	1/16W	5%	RMC1/16S 101JTH	J24189013		1	B	f3
R 1032	CHIP RES.	15k	1/16W	5%	RMC1/16S 153JTH	J24189039		1	B	g3
R 1033	CHIP RES.	3.3k	1/16W	5%	RMC1/16S 332JTH	J24189031		1	B	c2
R 1034	CHIP RES.	15k	1/16W	5%	RMC1/16S 153JTH	J24189039		1	B	d3
R 1036	CHIP RES.	10k	1/16W	5%	RMC1/16S 103JTH	J24189037		1	A	E2
R 1037	CHIP RES.	15k	1/16W	5%	RMC1/16S 153JTH	J24189039		1	B	f3
R 1038	CHIP RES.	4.7k	1/16W	5%	RMC1/16S 472JTH	J24189033		1	B	g3
R 1039	CHIP RES.	22k	1/16W	5%	RMC1/16S 223JTH	J24189041		1	B	b3
R 1041	CHIP RES.	10k	1/16W	5%	RMC1/16S 103JTH	J24189037		1	A	E2
R 1042	CHIP RES.	1M	1/16W	5%	RMC1/16S 105JTH	J24189061		1	B	b2
R 1044	CHIP RES.	4.7k	1/16W	5%	RMC1/16S 472JTH	J24189033		1	A	E2
R 1045	CHIP RES.	39k	1/16W	5%	RMC1/16S 393JTH	J24189044		1	B	g3
R 1047	CHIP RES.	10k	1/16W	5%	RMC1/16S 103JTH	J24189037		1	A	E2
R 1048	CHIP RES.	47k	1/16W	5%	RMC1/16S 473JTH	J24189045		1	B	g2
R 1049	CHIP RES.	1.5M	1/16W	5%	RMC1/16S 155JTH	J24189063		1	B	g3
R 1050	CHIP RES.	10k	1/16W	5%	RMC1/16S 103JTH	J24189037		1	B	c2
R 1051	CHIP RES.	5.6k	1/16W	5%	RMC1/16S 562JTH	J24189034		1	A	E2
R 1052	CHIP RES.	10k	1/16W	5%	RMC1/16S 103JTH	J24189037		1	B	g3
R 1053	CHIP RES.	5.6k	1/16W	5%	RMC1/16S 562JTH	J24189034		1	B	g3
R 1054	CHIP RES.	82k	1/16W	5%	RMC1/16S 823JTH	J24189048		1	B	c2
R 1056	CHIP RES.	47k	1/16W	5%	RMC1/16S 473JTH	J24189045		1	B	d4
R 1057	CHIP RES.	330k	1/16W	5%	RMC1/16S 334JTH	J24189055		1	B	c2
R 1058	CHIP RES.	2.7k	1/16W	5%	RMC1/16S 272JTH	J24189030		1	A	E2
R 1059	CHIP RES.	47k	1/16W	5%	RMC1/16S 473JTH	J24189045		1	B	d3
R 1060	CHIP RES.	6.8k	1/16W	5%	RMC1/16S 682JTH	J24189035		1	B	d3
R 1061	CHIP RES.	6.8k	1/16W	5%	RMC1/16S 682JTH	J24189035		1	B	d3
R 1062	CHIP RES.	220k	1/16W	5%	RMC1/16S 224JTH	J24189053		1	B	c3
R 1063	CHIP RES.	56k	1/16W	5%	RMC1/16S 563JTH	J24189046		1	B	g2
R 1064	CHIP RES.	56k	1/16W	5%	RMC1/16S 563JTH	J24189046		1	B	g2
R 1065	CHIP RES.	39k	1/16W	5%	RMC1/16S 393JTH	J24189044		1	B	g2
R 1066	CHIP RES.	390k	1/16W	5%	RMC1/16S 394JTH	J24189056		1	B	g2
R 1067	CHIP RES.	47k	1/16W	5%	RMC1/16S 473JTH	J24189045		1	B	g2
R 1068	CHIP RES.	68k	1/16W	5%	RMC1/16S 683JTH	J24189047		1	B	g2
R 1069	CHIP RES.	10k	1/16W	5%	RMC1/16S 103JTH	J24189037		1	B	b2
R 1070	CHIP RES.	39k	1/16W	5%	RMC1/16S 393JTH	J24189044		1	B	g3
R 1071	CHIP RES.	22k	1/16W	5%	RMC1/16S 223JTH	J24189041		1	A	C4
R 1072	CHIP RES.	10k	1/16W	5%	RMC1/16S 103JTH	J24189037		1	A	C2
R 1073	CHIP RES.	6.8k	1/16W	5%	RMC1/16S 682JTH	J24189035		1	B	d3
R 1074	CHIP RES.	4.7k	1/16W	5%	RMC1/16S 472JTH	J24189033		1	B	e3
R 1075	CHIP RES.	22k	1/16W	5%	RMC1/16S 223JTH	J24189041		1	B	e2
R 1076	CHIP RES.	680	1/16W	5%	RMC1/16S 681JTH	J24189023		1	B	e3
R 1077	CHIP RES.	47k	1/16W	5%	RMC1/16S 473JTH	J24189045		1	B	c2
R 1078	CHIP RES.	180k	1/16W	5%	RMC1/16S 184JTH	J24189052		1	A	C3
R 1079	CHIP RES.	1k	1/16W	5%	RMC1/16S 102JTH	J24189025		1	B	d2
R 1080	CHIP RES.	47k	1/16W	5%	RMC1/16S 473JTH	J24189045		1	A	C3
R 1081	CHIP RES.	10k	1/16W	5%	RMC1/16S 103JTH	J24189037		1	B	d2
R 1082	CHIP RES.	47k	1/16W	5%	RMC1/16S 473JTH	J24189045		1	B	e3
R 1083	CHIP RES.	10k	1/16W	5%	RMC1/16S 103JTH	J24189037		1	B	e2
R 1084	CHIP RES.	1.8k	1/16W	5%	RMC1/16S 182JTH	J24189028		1	B	d2
R 1085	CHIP RES.	47k	1/16W	5%	RMC1/16S 473JTH	J24189045		1	A	C3
R 1086	CHIP RES.	470	1/16W	5%	RMC1/16S 471JTH	J24189021		1	B	d2
R 1087	CHIP RES.	680	1/16W	5%	RMC1/16S 681JTH	J24189023		1	B	d2
R 1088	CHIP RES.	47k	1/16W	5%	RMC1/16S 473JTH	J24189045		1	A	C3
R 1089	CHIP RES.	470k	1/16W	5%	RMC1/16S 474JTH	J24189057		1	B	e3
R 1090	CHIP RES.	2.2k	1/16W	5%	RMC1/16S 222JTH	J24189029		1	B	e2
R 1091	CHIP RES.	220k	1/16W	5%	RMC1/16S 224JTH	J24189053		1	A	C3
R 1092	CHIP RES.	47k	1/16W	5%	RMC1/16S 473JTH	J24189045		1	B	e3
R 1093	CHIP RES.	2.2k	1/16W	5%	RMC1/16S 222JTH	J24189029		1	B	e2
R 1094	CHIP RES.	2.2k	1/16W	5%	RMC1/16S 222JTH	J24189029		1	B	e2
R 1095	CHIP RES.	33k	1/16W	5%	RMC1/16S 333JTH	J24189043		1	B	e3
R 1096	CHIP RES.	33k	1/16W	5%	RMC1/16S 333JTH	J24189043		1	A	C3

MAIN Unit

Parts List

REF.	DESCRIPTION	VALUE	V/W	TOL.	MFR'S DESIG	VXSTD P/N	VERS.	LOT.	SIDE	LAYADR
R 1097	CHIP RES.	2.2k	1/16W	5%	RMC1/16S 222JTH	J24189029		1	B	d2
R 1098	CHIP RES.	2.2k	1/16W	5%	RMC1/16S 222JTH	J24189029		1	B	d2
R 1100	CHIP RES.	10k	1/16W	5%	RMC1/16S 103JTH	J24189037		1	B	e3
R 1101	CHIP RES.	150	1/16W	5%	RMC1/16S 151JTH	J24189015		1	B	d2
R 1102	CHIP RES.	0	1/16W	5%	RMC1/16S JPTH	J24189070		1	B	e3
R 1103	CHIP RES.	470k	1/16W	5%	RMC1/16S 474JTH	J24189057		1	B	e2
R 1104	CHIP RES.	0	1/16W	5%	RMC1/16S JPTH	J24189070		1	B	e2
R 1105	CHIP RES.	56k	1/16W	5%	RMC1/16S 563JTH	J24189046		1	B	e3
R 1106	CHIP RES.	220k	1/16W	5%	RMC1/16S 224JTH	J24189053		1	B	e2
R 1107	CHIP RES.	12k	1/16W	5%	RMC1/16S 123JTH	J24189038		1	B	g1
R 1109	CHIP RES.	3.3k	1/16W	5%	RMC1/16S 332JTH	J24189031		1	B	g1
R 1110	CHIP RES.	220k	1/16W	5%	RMC1/16S 224JTH	J24189053		1	B	e2
R 1111	CHIP RES.	33k	1/16W	5%	RMC1/16S 333JTH	J24189043		1	B	d3
R 1112	CHIP RES.	33k	1/16W	5%	RMC1/16S 333JTH	J24189043		1	B	e3
R 1113	CHIP RES.	10k	1/16W	5%	RMC1/16S 103JTH	J24189037		1	B	d3
R 1114	CHIP RES.	3.3k	1/16W	5%	RMC1/16S 332JTH	J24189031		1	B	g1
R 1115	CHIP RES.	33k	1/16W	5%	RMC1/16S 333JTH	J24189043		1	B	d3
R 1116	CHIP RES.	33k	1/16W	5%	RMC1/16S 333JTH	J24189043		1	B	g1
R 1117	CHIP RES.	1k	1/16W	5%	RMC1/16S 102JTH	J24189025		1	B	e1
R 1118	CHIP RES.	100k	1/16W	5%	RMC1/16S 104JTH	J24189049		1	B	e1
R 1119	CHIP RES.	33k	1/16W	5%	RMC1/16S 333JTH	J24189043		1	B	d3
R 1120	CHIP RES.	120	1/16W	5%	RMC1/16S 121JTH	J24189014		1	B	a4
R 1121	CHIP RES.	22	1/16W	5%	RMC1/16S 220JTH	J24189005		1	B	f3
R 1122	CHIP RES.	22	1/16W	5%	RMC1/16S 220JTH	J24189005		1	B	f3
R 1123	CHIP RES.	100k	1/16W	5%	RMC1/16S 104JTH	J24189049		1	B	d3
R 1124	CHIP RES.	18	1/16W	5%	RMC1/16S 180JTH	J24189004		1	B	d1
R 1125	CHIP RES.	18	1/16W	5%	RMC1/16S 180JTH	J24189004		1	B	d1
R 1126	CHIP RES.	150k	1/16W	5%	RMC1/16S 154JTH	J24189051		1	B	d3
R 1127	CHIP RES.	100k	1/16W	5%	RMC1/16S 104JTH	J24189049		1	B	f2
R 1128	CHIP RES.	47k	1/16W	5%	RMC1/16S 473JTH	J24189045		1	B	e3
R 1129	CHIP RES.	18	1/16W	5%	RMC1/16S 180JTH	J24189004		1	B	d1
R 1130	CHIP RES.	1k	1/16W	5%	RMC1/16S 102JTH	J24189025		1	B	d1
R 1131	CHIP RES.	47k	1/16W	5%	RMC1/16S 473JTH	J24189045		1	B	f2
R 1132	CHIP RES.	33k	1/16W	5%	RMC1/16S 333JTH	J24189043		1	B	f1
R 1133	CHIP RES.	47k	1/16W	5%	RMC1/16S 473JTH	J24189045		1	B	d3
R 1134	CHIP RES.	3.3k	1/16W	5%	RMC1/16S 332JTH	J24189031		1	B	f1
R 1135	CHIP RES.	100k	1/16W	5%	RMC1/16S 104JTH	J24189049		1	B	f1
R 1136	CHIP RES.	3.3k	1/16W	5%	RMC1/16S 332JTH	J24189031		1	B	f1
R 1137	CHIP RES.	12k	1/16W	5%	RMC1/16S 123JTH	J24189038		1	B	f1
R 1138	CHIP RES.	68k	1/16W	5%	RMC1/16S 683JTH	J24189047		1	B	e3
R 1139	CHIP RES.	33k	1/16W	5%	RMC1/16S 333JTH	J24189043		1	B	e3
R 1140	CHIP RES.	4.7k	1/16W	5%	RMC1/16S 472JTH	J24189033		1	B	d1
R 1141	CHIP RES.	2.2k	1/16W	5%	RMC1/16S 222JTH	J24189029		1	B	d1
R 1142	CHIP RES.	47k	1/16W	5%	RMC1/16S 473JTH	J24189045		1	B	d1
R 1143	CHIP RES.	10k	1/16W	5%	RMC1/16S 103JTH	J24189037		1	A	D3
R 1144	CHIP RES.	1M	1/16W	5%	RMC1/16S 105JTH	J24189061		1	B	e3
R 1145	CHIP RES.	22k	1/16W	5%	RMC1/16S 223JTH	J24189041		1	B	d1
R 1146	CHIP RES.	2.2k	1/16W	5%	RMC1/16S 222JTH	J24189029		1	A	D2
R 1147	CHIP RES.	22	1/16W	5%	RMC1/16S 220JTH	J24189005		1	A	D2
R 1148	CHIP RES.	27k	1/16W	5%	RMC1/16S 273JTH	J24189042		1	A	D2
R 1149	CHIP RES.	100k	1/16W	5%	RMC1/16S 104JTH	J24189049		1	A	C2
R 1150	CHIP RES.	390k	1/16W	5%	RMC1/16S 394JTH	J24189056		1	B	e1
R 1151	CHIP RES.	33	1/16W	5%	RMC1/16S 330JTH	J24189007		1	B	d1
R 1152	CHIP RES.	10k	1/16W	5%	RMC1/16S 103JTH	J24189037		1	B	f3
R 1153	CHIP RES.	27k	1/16W	5%	RMC1/16S 273JTH	J24189042		1	A	D2
R 1154	CHIP RES.	2.2k	1/16W	5%	RMC1/16S 222JTH	J24189029		1	B	g2
R 1155	CHIP RES.	100	1/16W	5%	RMC1/16S 101JTH	J24189013		1	B	c1
R 1156	CHIP RES.	47	1/16W	5%	RMC1/16S 470JTH	J24189009		1	B	e1
R 1157	CHIP RES.	10k	1/16W	5%	RMC1/16S 103JTH	J24189037		1	A	D3
R 1158	CHIP RES.	270	1/16W	5%	RMC1/16S 271JTH	J24189018		1	B	e1
R 1159	CHIP RES.	10k	1/16W	5%	RMC1/16S 103JTH	J24189037		1	B	e3
R 1160	CHIP RES.	2.7k	1/16W	5%	RMC1/16S 272JTH	J24189030		1	B	e1
R 1161	CHIP RES.	3.3k	1/16W	5%	RMC1/16S 332JTH	J24189031		1	A	D3
R 1162	CHIP RES.	10k	1/16W	5%	RMC1/16S 103JTH	J24189037		1	A	D2
R 1163	CHIP RES.	47	1/16W	5%	RMC1/16S 470JTH	J24189009		1	B	c2
R 1164	CHIP RES.	100k	1/16W	5%	RMC1/16S 104JTH	J24189049		1	B	c1
R 1165	CHIP RES.	220k	1/16W	5%	RMC1/16S 224JTH	J24189053		1	A	C2

MAIN Unit

Parts List

REF.	DESCRIPTION	VALUE	V/W	TOL.	MFR'S DESIG	VXSTD P/N	VERS.	LOT.	SIDE	LAY ADR
R 1167	CHIP RES.	0	1/16W	5%	RMC1/16S JPTH	J24189070		1	B	c1
R 1168	CHIP RES.	150k	1/16W	5%	RMC1/16S 154JTH	J24189051		1	B	e1
R 1169	CHIP RES.	3.9k	1/16W	5%	RMC1/16S 392JTH	J24189032		1	B	e1
R 1170	CHIP RES.	47	1/10W	5%	RMC1/10T 470J	J24205470		1	B	c2
R 1174	CHIP RES.	2.2k	1/16W	5%	RMC1/16S 222JTH	J24189029		1	B	g2
R 1175	CHIP RES.	47k	1/16W	5%	RMC1/16S 473JTH	J24189045		1	B	c1
R 1176	CHIP RES.	100k	1/16W	5%	RMC1/16S 104JTH	J24189049		1	B	d1
R 1178	CHIP RES.	5.6k	1/16W	5%	RMC1/16S 562JTH	J24189034		1	A	C2
R 1179	CHIP RES.	100k	1/16W	5%	RMC1/16S 104JTH	J24189049		1	A	C1
R 1180	CHIP RES.	1k	1/16W	5%	RMC1/16S 102JTH	J24189025		1	B	c1
R 1181	CHIP RES.	100k	1/16W	5%	RMC1/16S 104JTH	J24189049		1	B	c1
R 1182	CHIP RES.	33	1/16W	5%	RMC1/16S 330JTH	J24189007		1	A	C1
R 1183	CHIP RES.	15k	1/16W	5%	RMC1/16S 153JTH	J24189039		1	A	D2
R 1184	CHIP RES.	1k	1/16W	5%	RMC1/16S 102JTH	J24189025		1	A	D2
R 1185	CHIP RES.	1k	1/16W	5%	RMC1/16S 102JTH	J24189025		1	B	e1
R 1186	CHIP RES.	220k	1/16W	5%	RMC1/16S 224JTH	J24189053		1	A	F1
R 1187	CHIP RES.	100k	1/16W	5%	RMC1/16S 104JTH	J24189049		1	B	d1
R 1188	CHIP RES.	100k	1/16W	5%	RMC1/16S 104JTH	J24189049		1	A	D1
R 1189	CHIP RES.	33k	1/16W	5%	RMC1/16S 333JTH	J24189043		1	A	F1
R 1191	CHIP RES.	4.7k	1/16W	5%	RMC1/16S 472JTH	J24189033		1	B	f2
R 1192	CHIP RES.	560	1/16W	5%	RMC1/16S 561JTH	J24189022		1	A	C1
R 1193	CHIP RES.	27k	1/16W	5%	RMC1/16S 273JTH	J24189042		1	A	D1
R 1194	CHIP RES.	68k	1/16W	5%	RMC1/16S 683JTH	J24189047		1	A	E1
R 1195	CHIP RES.	100k	1/16W	5%	RMC1/16S 104JTH	J24189049		1	B	d1
R 1196	CHIP RES.	470k	1/16W	5%	RMC1/16S 474JTH	J24189057		1	B	d1
R 1197	CHIP RES.	2.7k	1/16W	5%	RMC1/16S 272JTH	J24189030		1	A	E1
R 1198	CHIP RES.	1k	1/16W	5%	RMC1/16S 102JTH	J24189025		1	A	E1
R 1199	CHIP RES.	180	1/16W	5%	RMC1/16S 181JTH	J24189016		1	A	F1
R 1200	CHIP RES.	68k	1/16W	5%	RMC1/16S 683JTH	J24189047		1	A	D1
R 1202	CHIP RES.	560	1/16W	5%	RMC1/16S 561JTH	J24189022		1	B	c1
R 1203	CHIP RES.	560	1/16W	5%	RMC1/16S 561JTH	J24189022		1	B	c1
R 1204	CHIP RES.	33k	1/16W	5%	RMC1/16S 333JTH	J24189043		1	A	F1
R 1206	CHIP RES.	33k	1/16W	5%	RMC1/16S 333JTH	J24189043		1	A	F1
R 1207	CHIP RES.	47k	1/16W	5%	RMC1/16S 473JTH	J24189045		1	A	D1
R 1208	CHIP RES.	10k	1/16W	5%	RMC1/16S 103JTH	J24189037		1	A	F1
R 1209	CHIP RES.	82k	1/16W	5%	RMC1/16S 823JTH	J24189048		1	B	c1
R 1210	CHIP RES.	10	1/16W	5%	RMC1/16S 100JTH	J24189001		1	A	E1
R 1211	CHIP RES.	10k	1/16W	5%	RMC1/16S 103JTH	J24189037		1	A	F1
R 1212	CHIP RES.	33k	1/16W	5%	RMC1/16S 333JTH	J24189043		1	A	F1
R 1213	CHIP RES.	33k	1/16W	5%	RMC1/16S 333JTH	J24189043		1	A	F1
R 1214	CHIP RES.	100k	1/16W	5%	RMC1/16S 104JTH	J24189049		1	B	d1
R 1216	CHIP RES.	22k	1/16W	5%	RMC1/16S 223JTH	J24189041		1	B	f2
R 1217	CHIP RES.	22k	1/16W	5%	RMC1/16S 223JTH	J24189041		1	B	f3
R 1218	CHIP RES.	10k	1/16W	5%	RMC1/16S 103JTH	J24189037		1	A	F1
R 1219	CHIP RES.	10k	1/16W	5%	RMC1/16S 103JTH	J24189037		1	A	F1
R 1220	CHIP RES.	4.7k	1/16W	5%	RMC1/16S 472JTH	J24189033		1	B	g3
TC1001	TRIMMER CAP.	20pF			CTZ2S-20C-W2-P	K91000216		1	B	e1
TH1001	THERMISTOR				TBPS1R473K475H5Q	G9090068		1	A	E2
TH1002	THERMISTOR				TBPS1R473K475H5Q	G9090068		1	A	D2
TH1003	THERMISTOR				ERTJ0ET102J	G9090131		1	B	c1
TH1004	THERMISTOR				TBPS1R472K440H5Q	G9090066		1	B	g3
VR1001	POT.	10k			POZ3AN-1-103N-T00	J51820103		1	B	f2
VR1002	POT.	10k			POZ3AN-1-103N-T00	J51820103		1	B	f2
VR1003	POT.	10k			POZ3AN-1-103N-T00	J51820103		1	B	f2
X 1001	XTAL SX-1319	3.6864MHz			3.6864MHZ	H0103214		1	B	b2
X 1002	XTAL TOP-B	17.475MHz			17.475MHZ	H0103231		1	B	f1
XF1001	XTAL FILTER				35S15A	H1102335		1	A	C1
	SHIELD FINGER				4025 3100089	S5000225		1	A	E3
	SHIELD FINGER				4025 3100089	S5000225		1	A	E2
	TERMINAL PLATE R				(MIC)	RA0107000		1		
	HOLDER RUBBER					RA0110200		1		
	BRACKET					RA0209600		1		
	HOLDER					RA0210100		1		
	LIGHT GUIDE					RA020950A		1		
	TERMINAL PLATE					RA0210700		1		
	COPPER TAPE				(10X2.7)	RA0384400		1		

VR Unit

Parts Layout

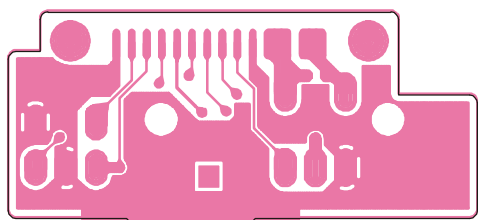

Side A

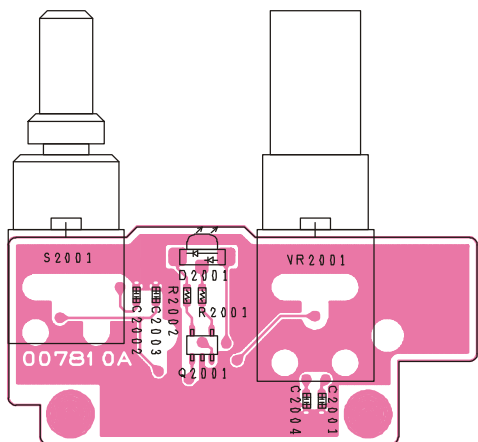

Side B

Circuit Diagram

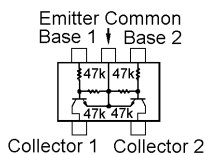
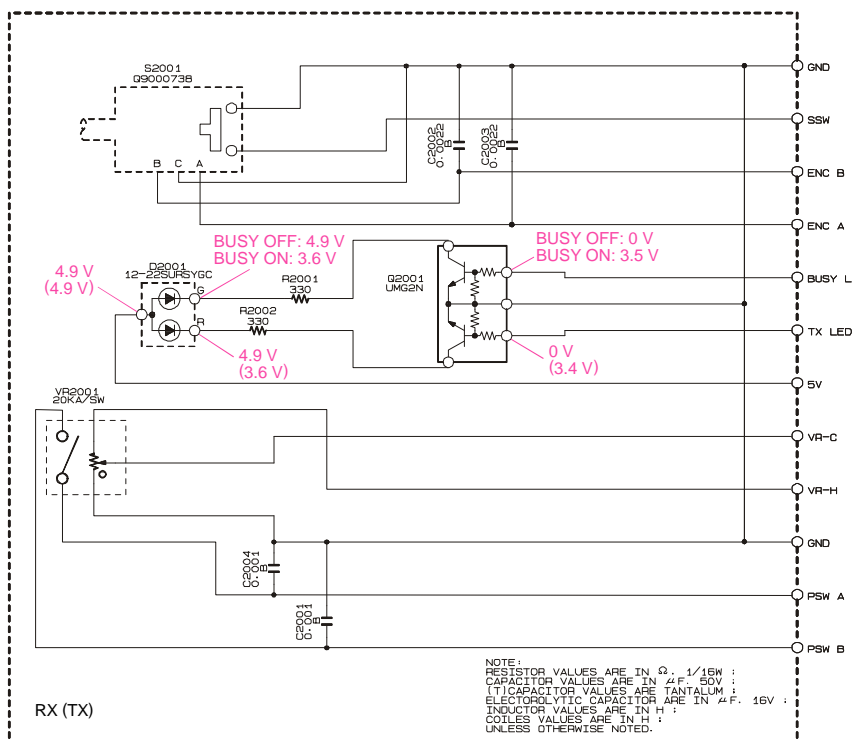

UMG2N (G2)
(Q2001)

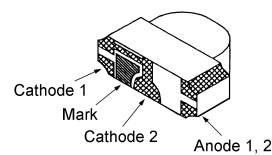

12-22SURSYGC
(D2001)

Parts List

REF.	DESCRIPTION	VALUE	V/W	TOL.	MFR'S DESIG	VXSTD P/N	VERS.	LOT.	SIDE	LAY ADR
PCB with Components						CB1861001				
Printed Circuit Board						FR0078100		1		
C 2001	CHIP CAP.	0.001uF	50V	B	UMK105B102KW-F	K22178829		1	B	
C 2002	CHIP CAP.	0.0022uF	50V	B	UMK105B222KW-F	K22178833		1	B	
C 2003	CHIP CAP.	0.0022uF	50V	B	UMK105B222KW-F	K22178833		1	B	
C 2004	CHIP CAP.	0.001uF	50V	B	UMK105B102KW-F	K22178829		1	B	
D 2001	LED				12-22SURSYGC	G2070810		1	B	
Q 2001	TRANSISTOR				UMG2N TR	G3070088		1	B	
R 2001	CHIP RES.	330	1/16W	5%	RMC1/16S 331JTH	J24189019		1	B	
R 2002	CHIP RES.	330	1/16W	5%	RMC1/16S 331JTH	J24189019		1	B	
S 2001	ROTARY ENCODER				TP70N17AE20	Q9000738		1	B	
VR2001	POT.				TP76N00N 20KA/SW	J60800236		1	B	

SW Unit

Circuit Diagram

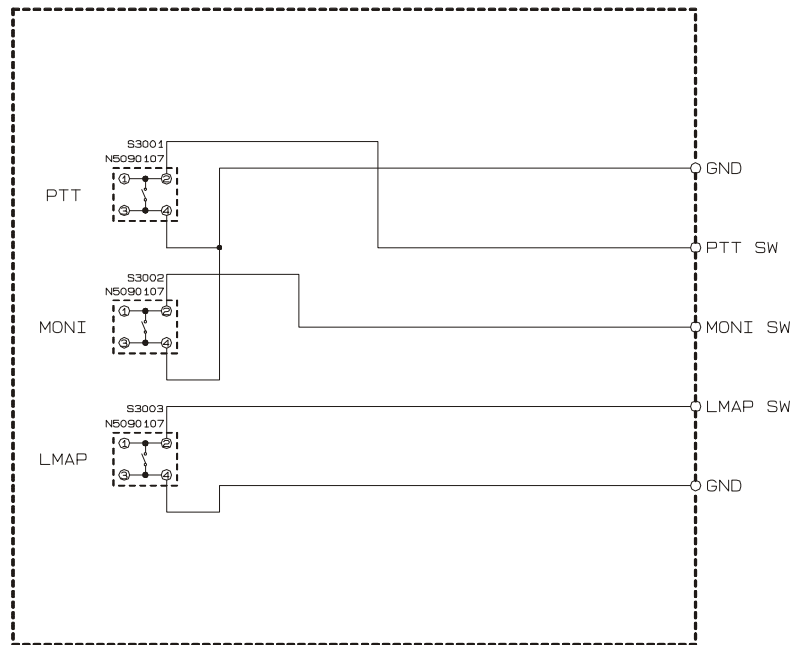

Parts Layout

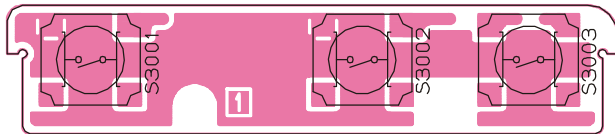

Side A



Side B

Parts List

REF.	DESCRIPTION	VALUE	V/W	TOL.	MFR'S DESIG	VXSTD P/N	VERS.	LOT.	SIDE	LAY ADR
PCB with Components						CB1862001				
Printed Circuit Board						FR0026500		1		
S 3001	TACT SWITCH				SOP-114HST R66-5374	N5090107		1	A	
S 3002	TACT SWITCH				SOP-114HST R66-5374	N5090107		1	A	
S 3003	TACT SWITCH				SOP-114HST R66-5374	N5090107		1	A	



Copyright © 2001
VERTEX STANDARD CO., LTD.
All rights reserved.

No portion of this manual
may be reproduced
without the permission of
VERTEX STANDARD CO., LTD.

Printed in Japan

